

09

# Index Concurrency



Intro to Database Systems  
15-445/15-645  
Fall 2019

AP

Andy Pavlo  
Computer Science  
Carnegie Mellon University

# ADMINISTRIVIA

---

**Project #1** is due Fri Sept 27<sup>th</sup> @ 11:59pm

**Homework #2** is due Mon Sept 30<sup>th</sup> @ 11:59pm

**Project #2** will be released Mon Sept 30<sup>th</sup>



# OBSERVATION

---

We assumed that all the data structures that we have discussed so far are single-threaded.

But we need to allow multiple threads to safely access our data structures to take advantage of additional CPU cores and hide disk I/O stalls.



They Don't Do This!

# CONCURRENCY CONTROL

---

A **concurrency control** protocol is the method that the DBMS uses to ensure "correct" results for concurrent operations on a shared object.

A protocol's correctness criteria can vary:

→ **Logical Correctness:** Can I see the data that I am supposed to see?

→ **Physical Correctness:** Is the internal representation of the object sound?

# TODAY'S AGENDA

---

Latches Overview

Hash Table Latching

B+Tree Latching

Leaf Node Scans

Delayed Parent Updates



# LOCKS VS. LATCHES

---

## Locks

- Protects the database's logical contents from other txns.
- Held for txn duration.
- Need to be able to rollback changes.

## Latches

- Protects the critical sections of the DBMS's internal data structure from other threads.
- Held for operation duration.
- Do not need to be able to rollback changes.



# LOCKS VS. LATCHES

Lecture 17

## *Locks*

<b>Separate...</b>	User transactions
<b>Protect...</b>	Database Contents
<b>During...</b>	Entire Transactions
<b>Modes...</b>	Shared, Exclusive, Update, Intention
<b>Deadlock</b>	Detection & Resolution
<b>...by...</b>	Waits-for, Timeout, Aborts
<b>Kept in...</b>	Lock Manager

## *Latches*

Threads
In-Memory Data Structures
Critical Sections
Read, Write
Avoidance
Coding Discipline
Protected Data Structure

# LATCH MODES

## Read Mode

- Multiple threads can read the same object at the same time.
- A thread can acquire the read latch if another thread has it in read mode.

## Write Mode

- Only one thread can access the object.
- A thread cannot acquire a write latch if another thread holds the latch in any mode.

Compatibility Matrix

	Read	Write
Read	✓	✗
Write	✗	✗



# LATCH IMPLEMENTATIONS

---

## Approach #1: Blocking OS Mutex

- Simple to use
- Non-scalable (about 25ns per lock/unlock invocation)
- Example: `std::mutex`

```
std::mutex m;  
:  
m.lock();  
// Do something special...  
m.unlock();
```

# LATCH IMPLEMENTATIONS

---

## Approach #2: Test-and-Set Spin Latch (TAS)

- Very efficient (single instruction to latch/unlatch)
- Non-scalable, not cache friendly
- Example: `std::atomic<T>`

*std::atomic<bool>*

```
std::atomic_flag latch;  
:  
while (latch.test_and_set(...)) {  
    // Retry? Yield? Abort?  
}
```

# LATCH IMPLEMENTATIONS

---

## Approach #3: Reader-Writer Latch

- Allows for concurrent readers
- Must manage read/write queues to avoid starvation
- Can be implemented on top of spinlocks

### *Latch*

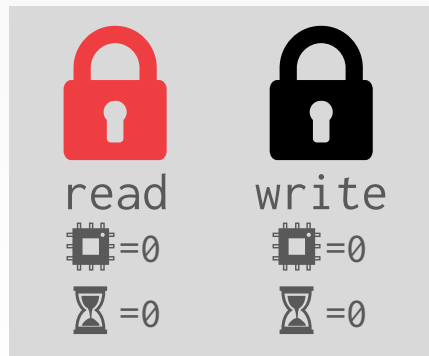

# LATCH IMPLEMENTATIONS

## Approach #3: Reader-Writer Latch

- Allows for concurrent readers
- Must manage read/write queues to avoid starvation
- Can be implemented on top of spinlocks

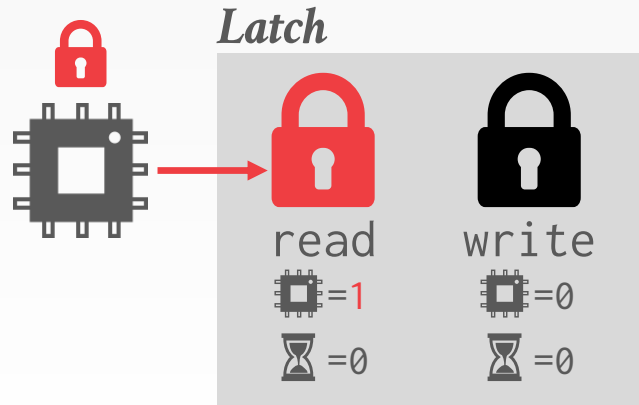

# LATCH IMPLEMENTATIONS

## Approach #3: Reader-Writer Latch

- Allows for concurrent readers
- Must manage read/write queues to avoid starvation
- Can be implemented on top of spinlocks

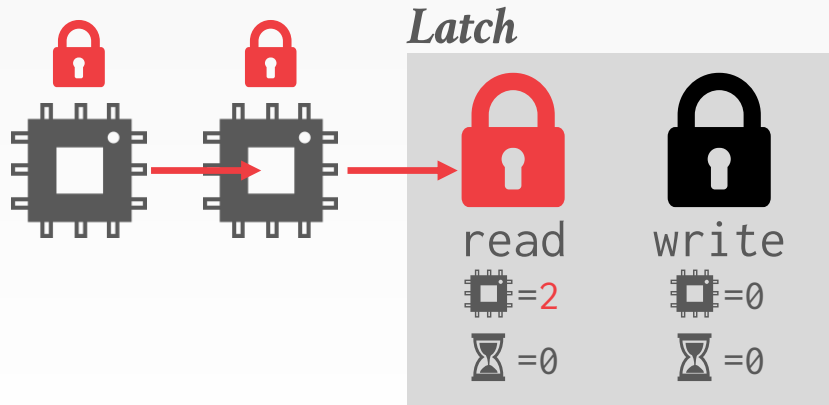

# LATCH IMPLEMENTATIONS

## Approach #3: Reader-Writer Latch

- Allows for concurrent readers
- Must manage read/write queues to avoid starvation
- Can be implemented on top of spinlocks

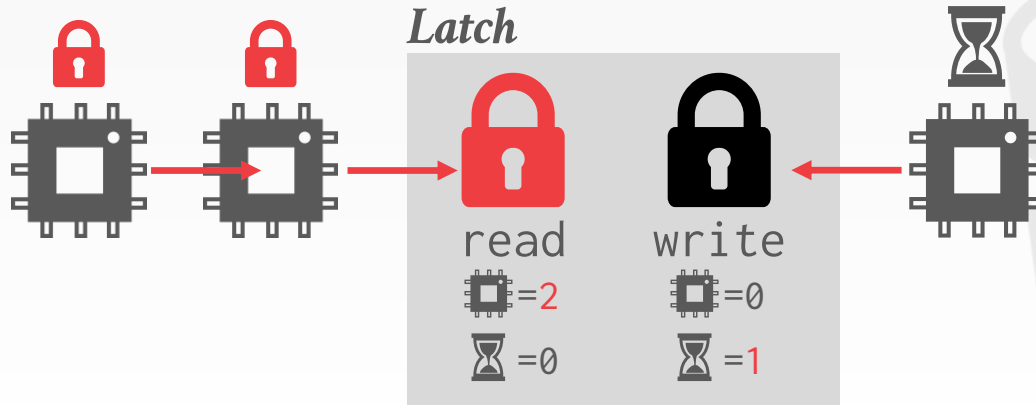

# LATCH IMPLEMENTATIONS

## Approach #3: Reader-Writer Latch

- Allows for concurrent readers
- Must manage read/write queues to avoid starvation
- Can be implemented on top of spinlocks

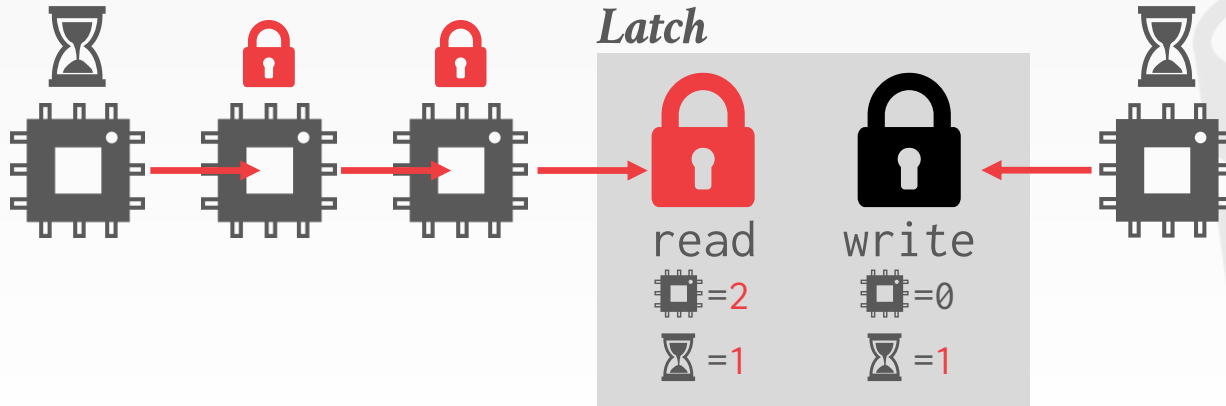

# HASH TABLE LATCHING

---

Easy to support concurrent access due to the limited ways threads access the data structure.

- All threads move in the same direction and only access a single page/slot at a time.
- Deadlocks are not possible.

To resize the table, take a global latch on the entire table (i.e., in the header page).





# HASH TABLE LATCHING

---

## **Approach #1: Page Latches**

- Each page has its own reader-write latch that protects its entire contents.
- Threads acquire either a read or write latch before they access a page.

## **Approach #2: Slot Latches**

- Each slot has its own latch.
- Can use a single mode latch to reduce meta-data and computational overhead.



# HASH TABLE – PAGE LATCHES

$T_1$ : Find D

$hash(D)$

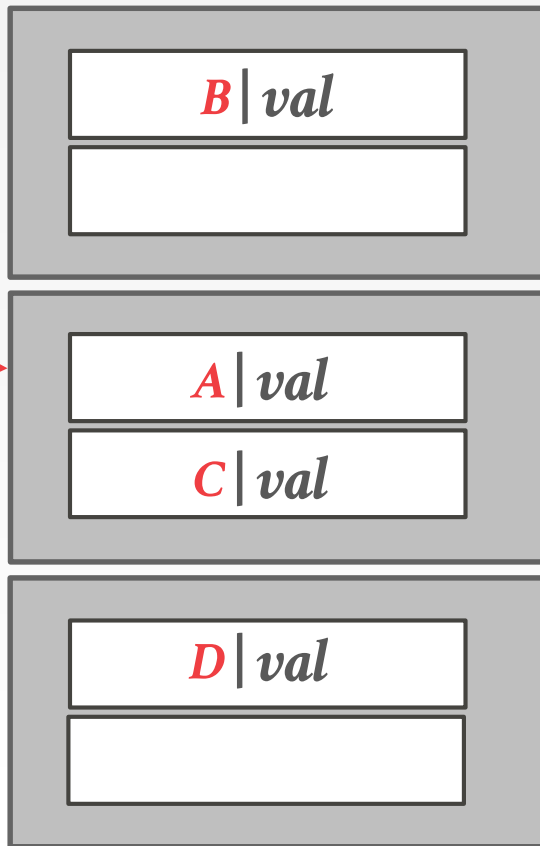

# HASH TABLE – PAGE LATCHES

$T_1$ : Find D  
*hash(D)*

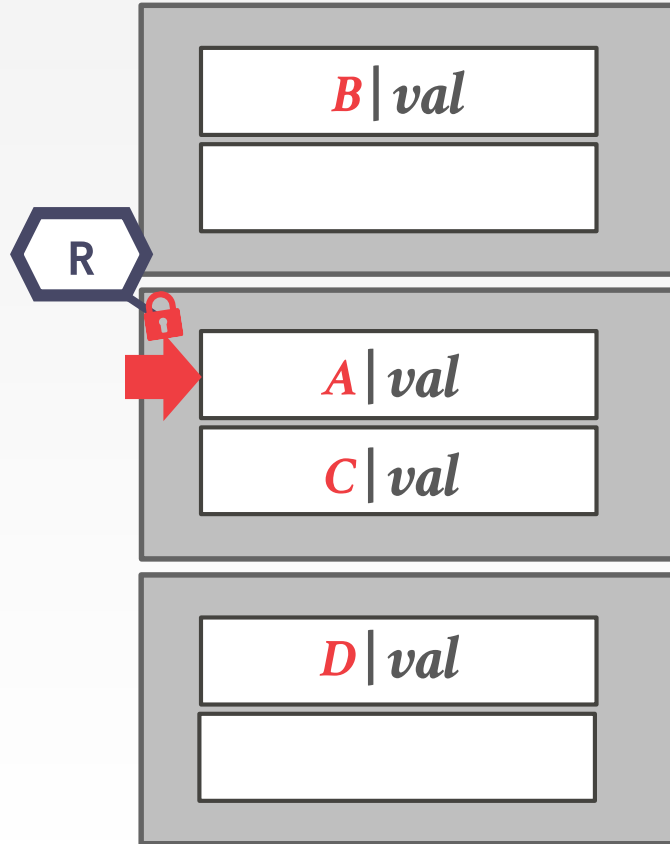

# HASH TABLE – PAGE LATCHES

$T_1$ : Find D  
*hash(D)*

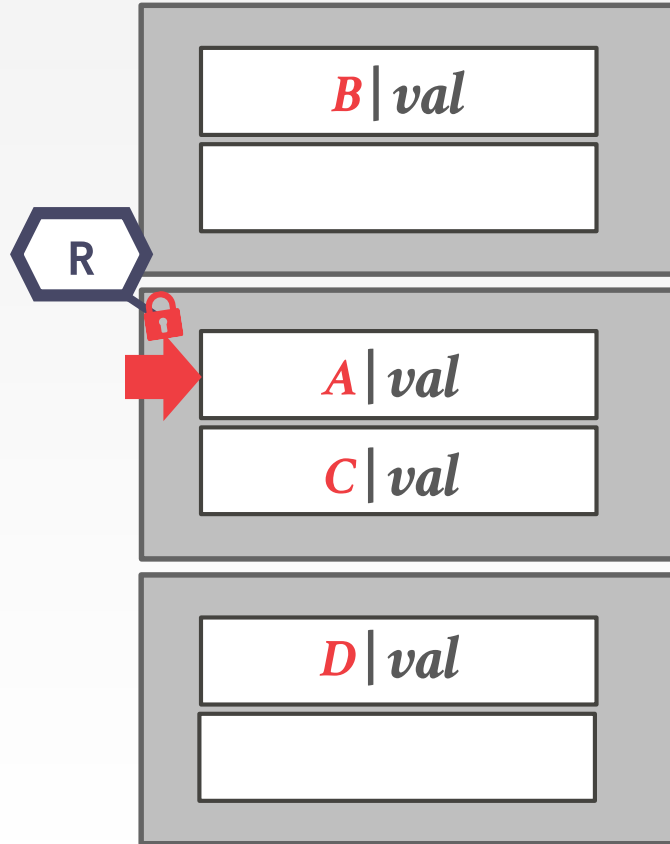

$T_2$ : Insert E  
*hash(E)*

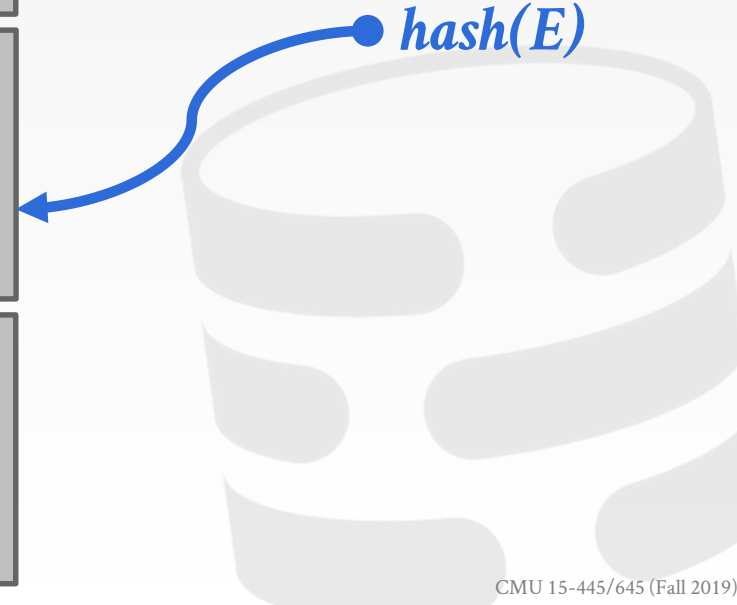

# HASH TABLE – PAGE LATCHES

$T_1$ : Find D  
*hash(D)*

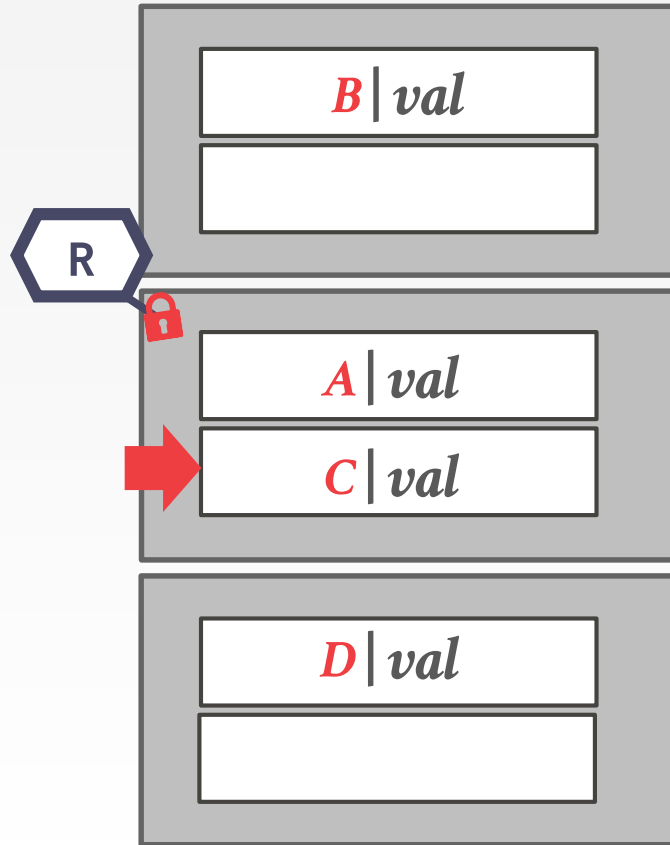

$T_2$ : Insert E  
*hash(E)*

# HASH TABLE – PAGE LATCHES

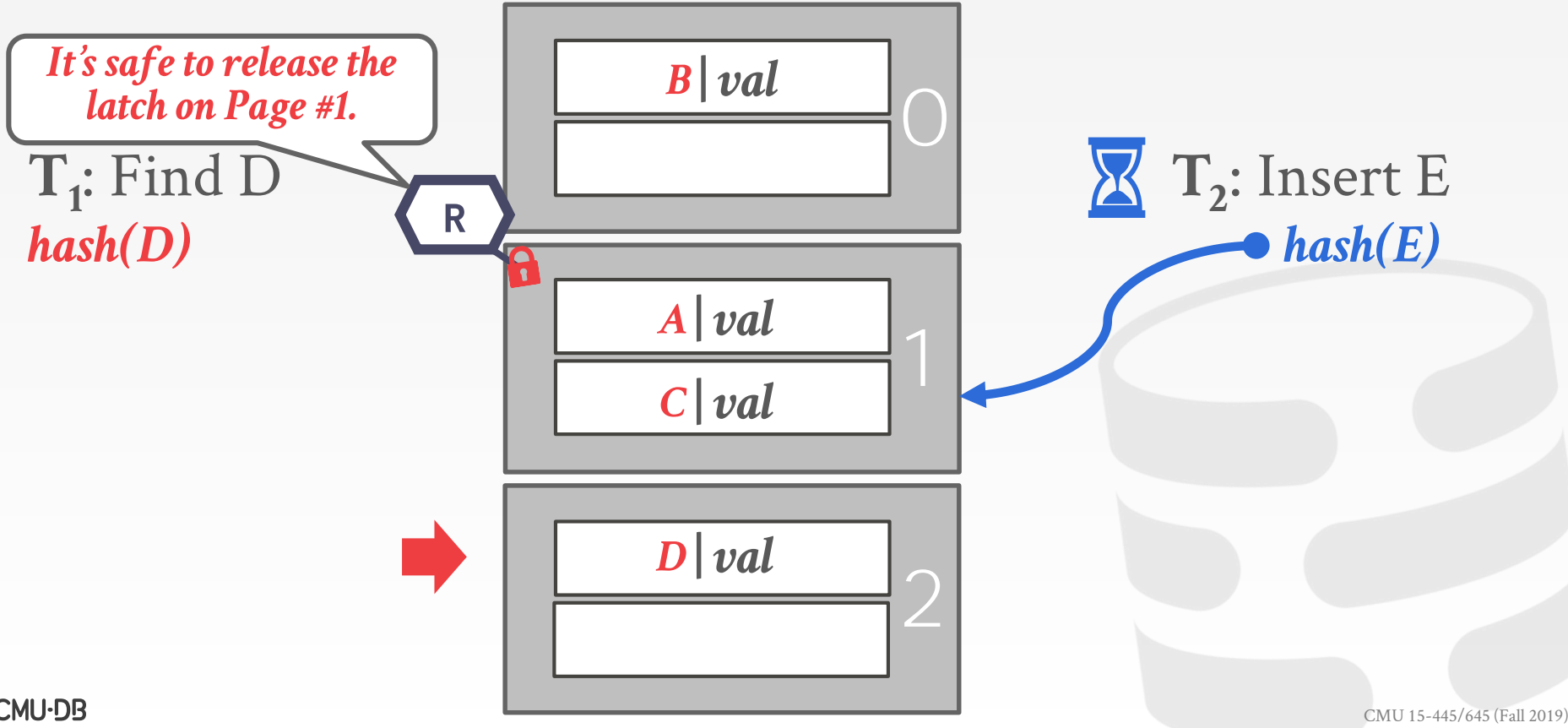

# HASH TABLE – PAGE LATCHES

$T_1$ : Find D  
*hash(D)*

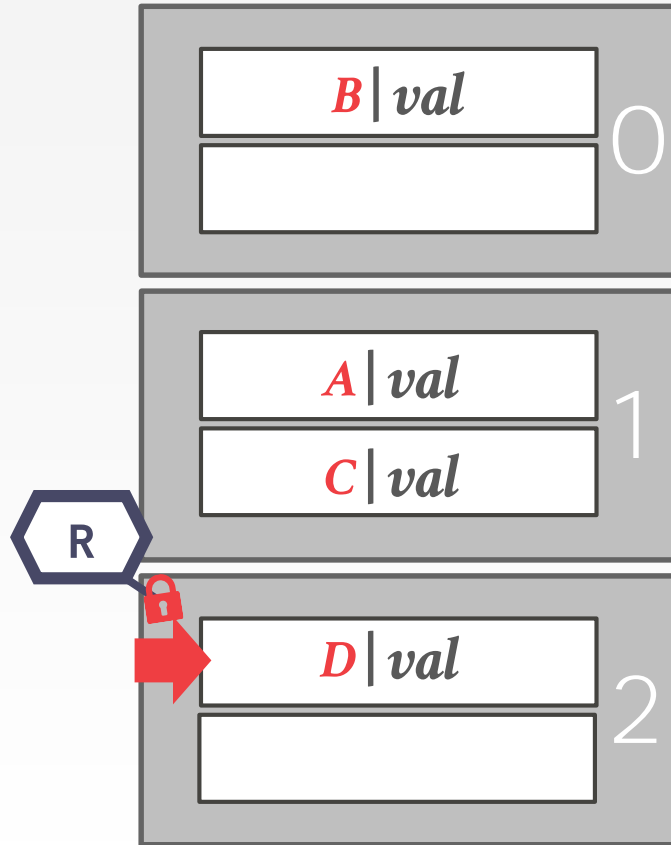

$T_2$ : Insert E  
*hash(E)*

# HASH TABLE – PAGE LATCHES

$T_1$ : Find D  
*hash(D)*

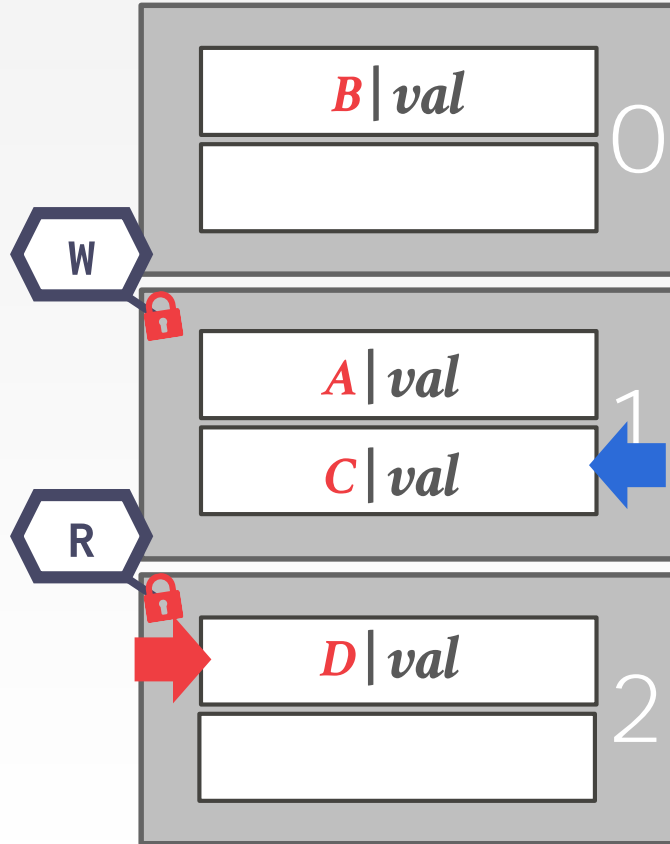

$T_2$ : Insert E  
*hash(E)*



# HASH TABLE – PAGE LATCHES

$T_1$ : Find D  
*hash(D)*

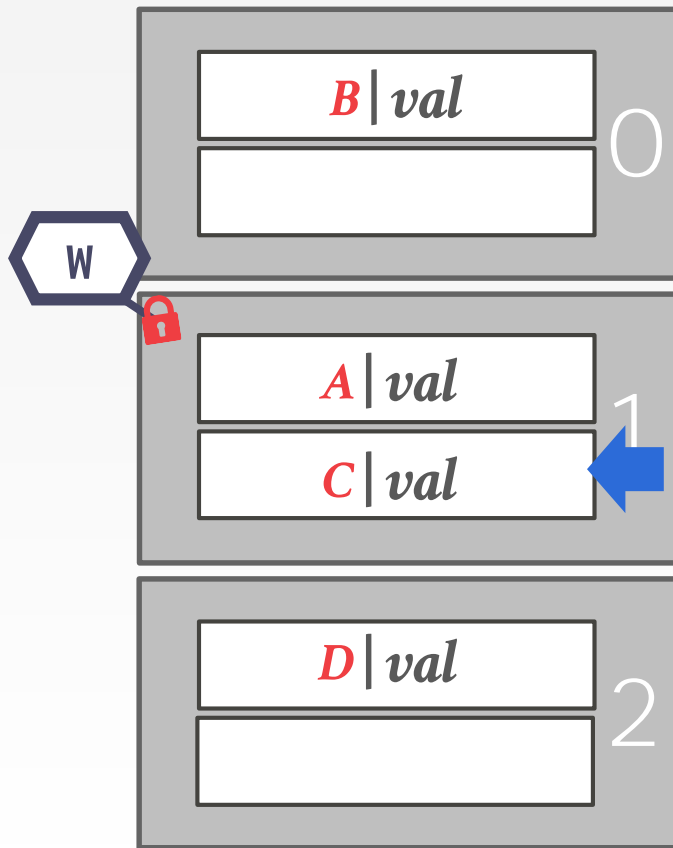

$T_2$ : Insert E  
*hash(E)*

# HASH TABLE – PAGE LATCHES

$T_1$ : Find D  
*hash(D)*

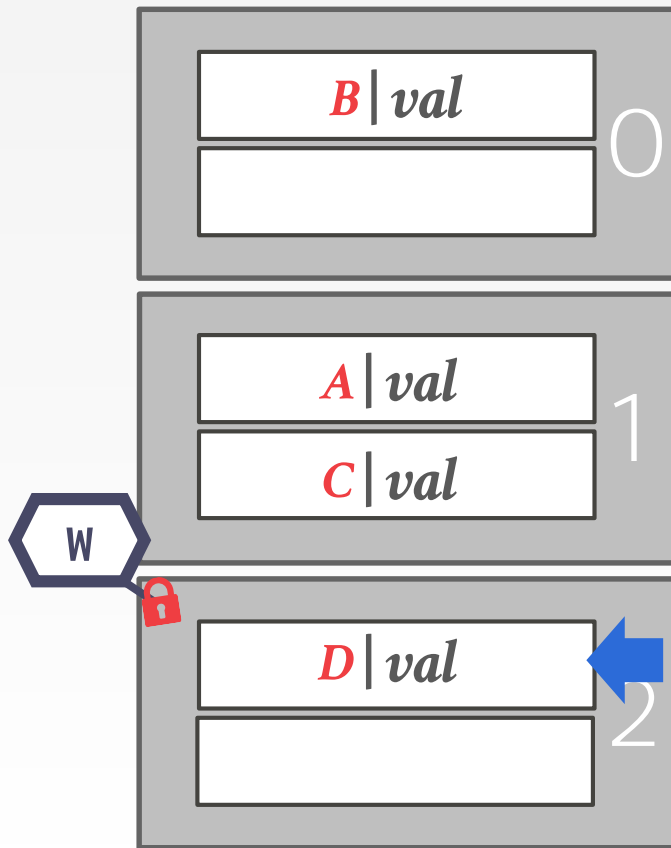

$T_2$ : Insert E  
*hash(E)*



# HASH TABLE – PAGE LATCHES

$T_1$ : Find D  
*hash(D)*

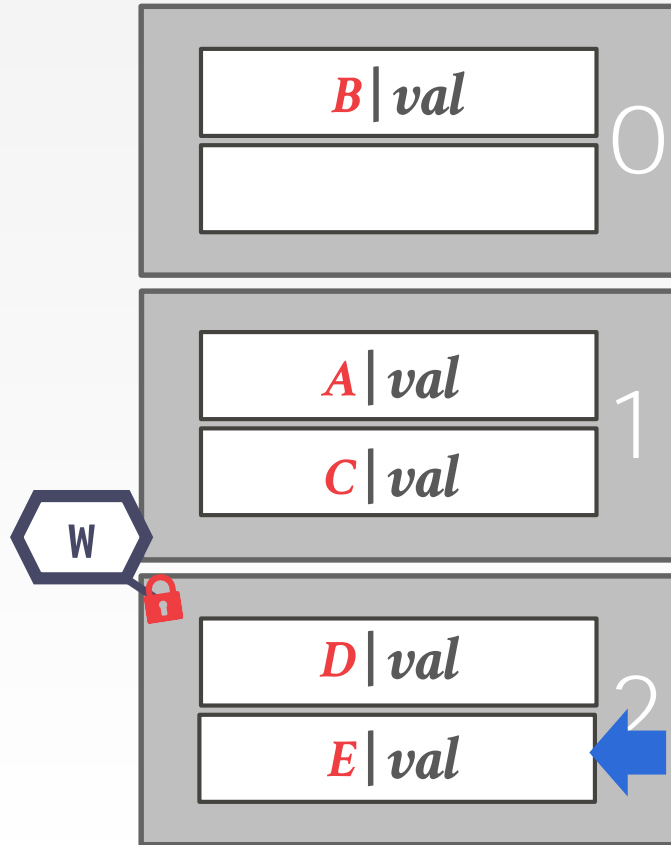

$T_2$ : Insert E  
*hash(E)*



# HASH TABLE – SLOT LATCHES

$T_1$ : Find D

$hash(D)$

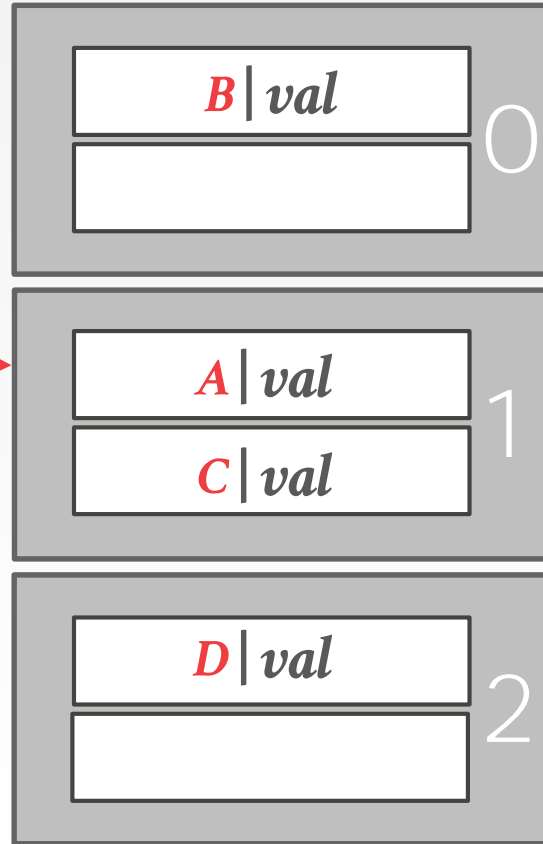

$T_2$ : Insert E

$hash(E)$



# HASH TABLE – SLOT LATCHES

$T_1$ : Find D  
*hash(D)*

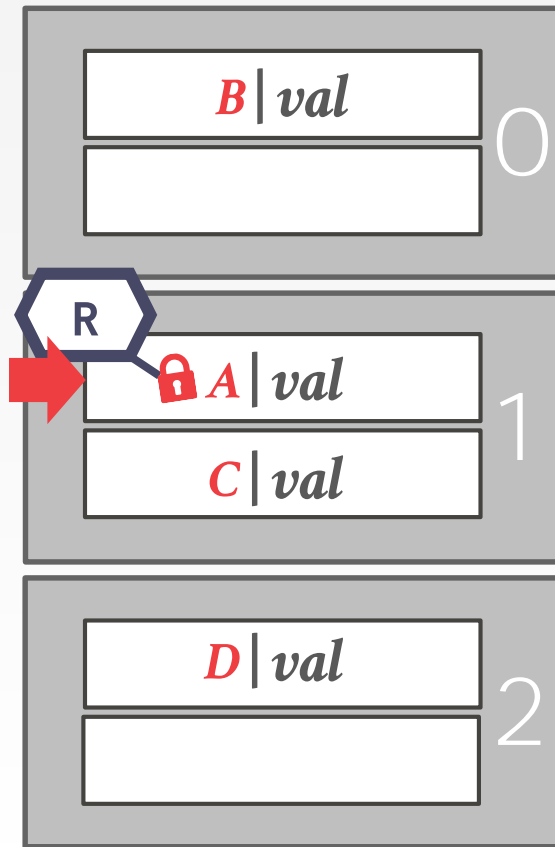

$T_2$ : Insert E  
*hash(E)*



# HASH TABLE – SLOT LATCHES

$T_1$ : Find D  
*hash(D)*

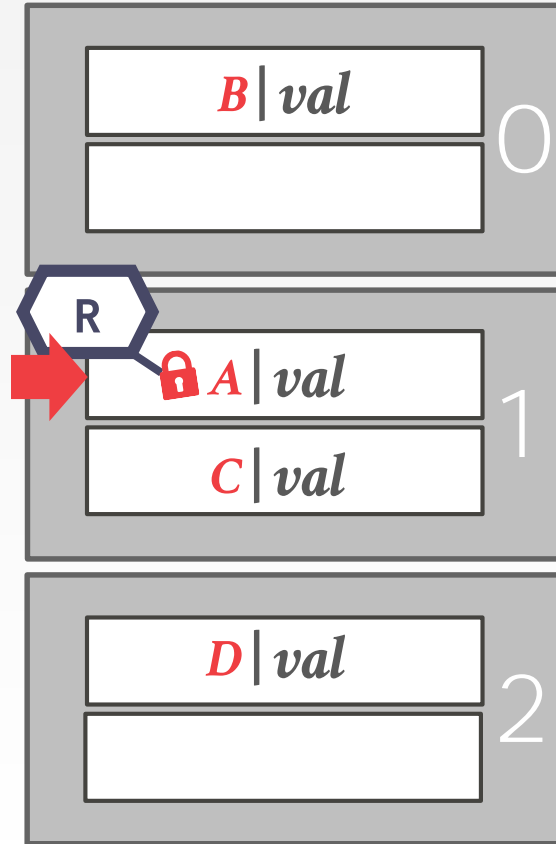

$T_2$ : Insert E  
*hash(E)*

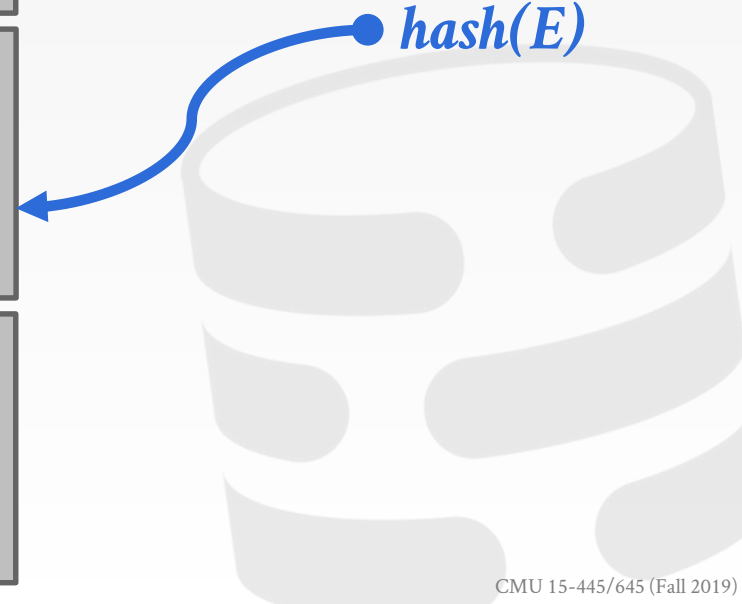

# HASH TABLE – SLOT LATCHES

$T_1$ : Find D  
*hash(D)*

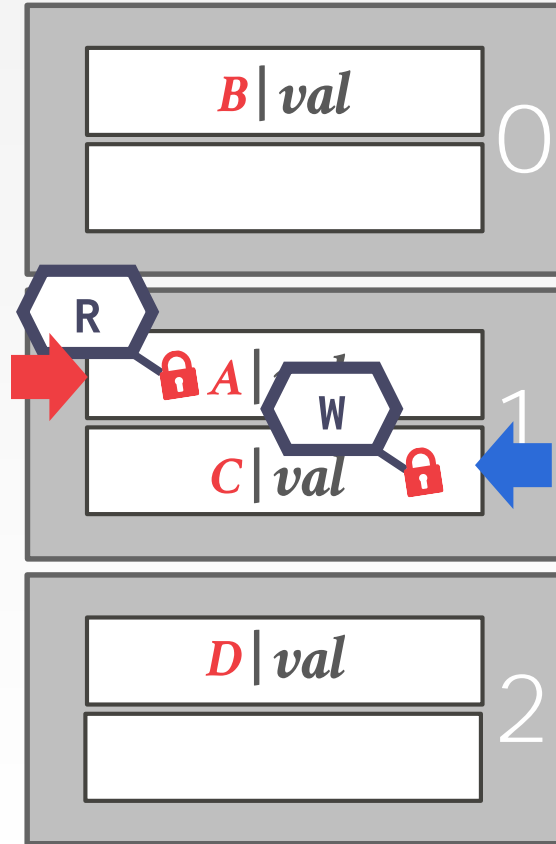

$T_2$ : Insert E  
*hash(E)*

# HASH TABLE – SLOT LATCHES

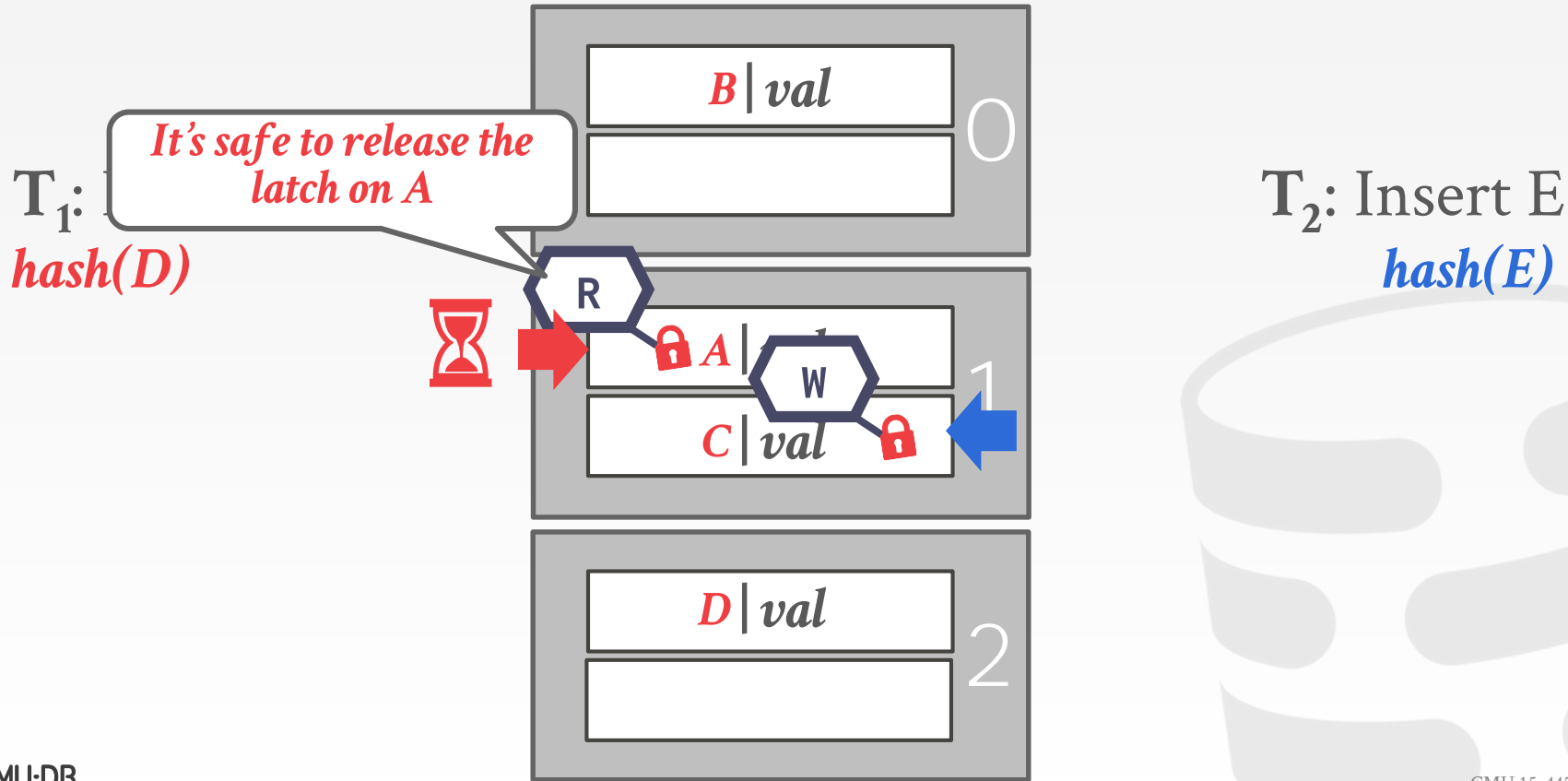



# HASH TABLE – SLOT LATCHES

$T_1$ : Find D  
*hash(D)*

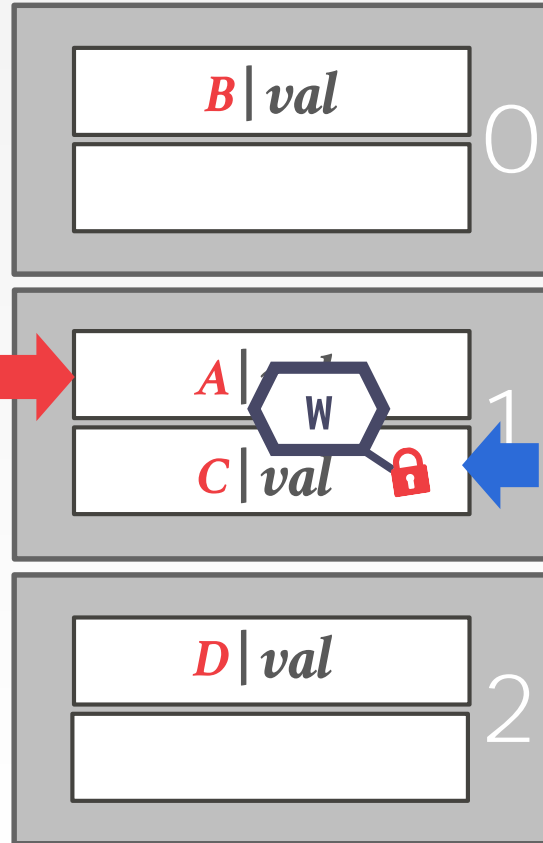

$T_2$ : Insert E  
*hash(E)*



# HASH TABLE – SLOT LATCHES

$T_1$ : Find D  
*hash(D)*

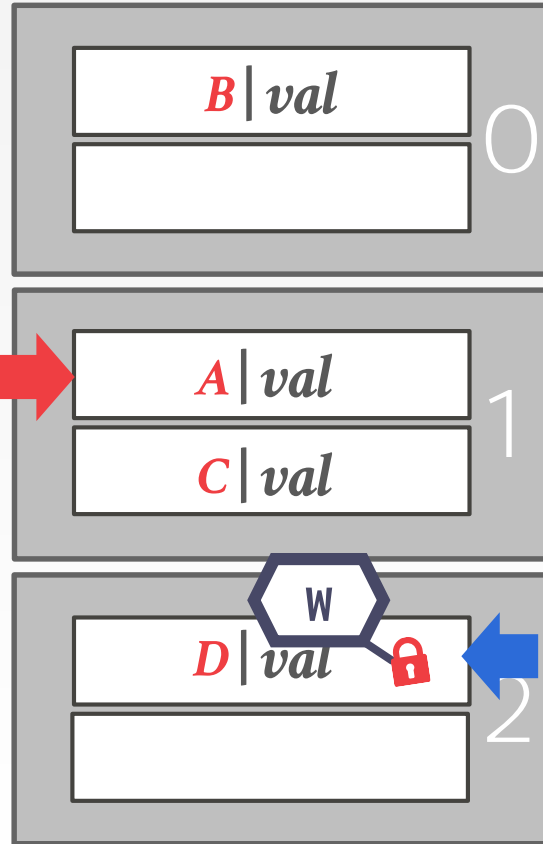

$T_2$ : Insert E  
*hash(E)*

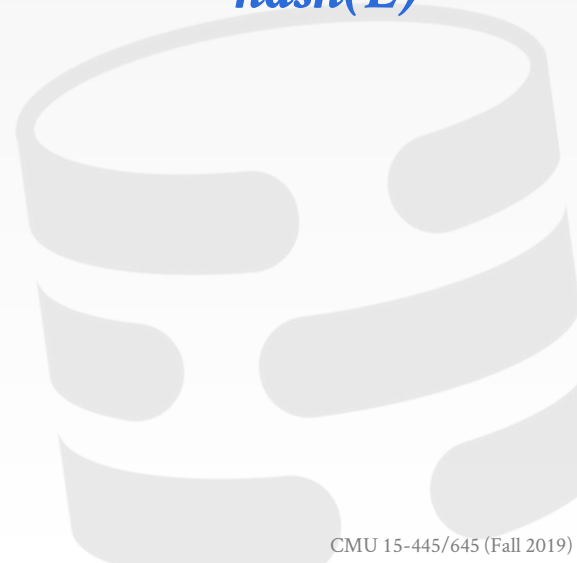

# HASH TABLE – SLOT LATCHES

$T_1$ : Find D  
*hash(D)*

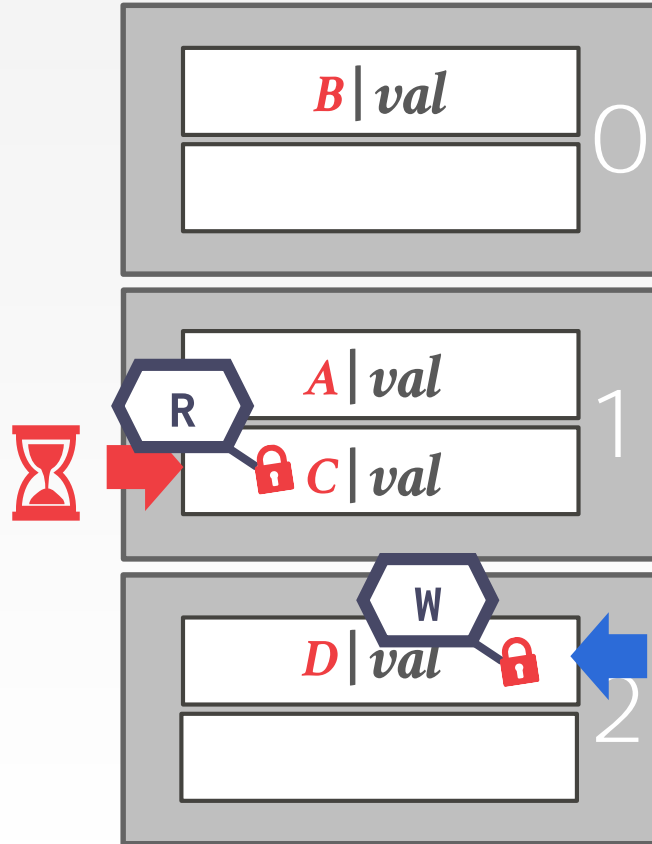

$T_2$ : Insert E  
*hash(E)*



# HASH TABLE – SLOT LATCHES

$T_1$ : Find D  
*hash(D)*

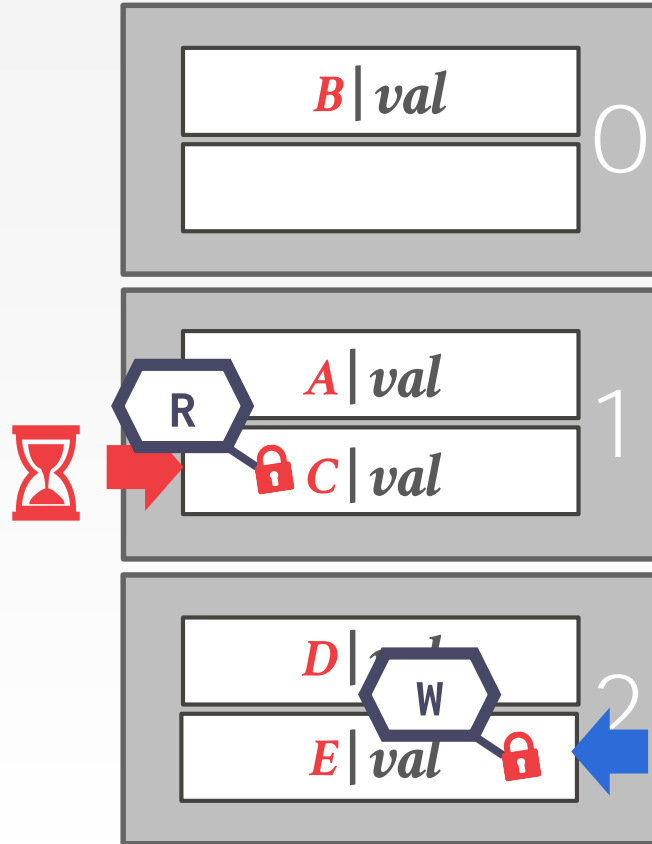

$T_2$ : Insert E  
*hash(E)*



# HASH TABLE – SLOT LATCHES

$T_1$ : Find D  
*hash(D)*

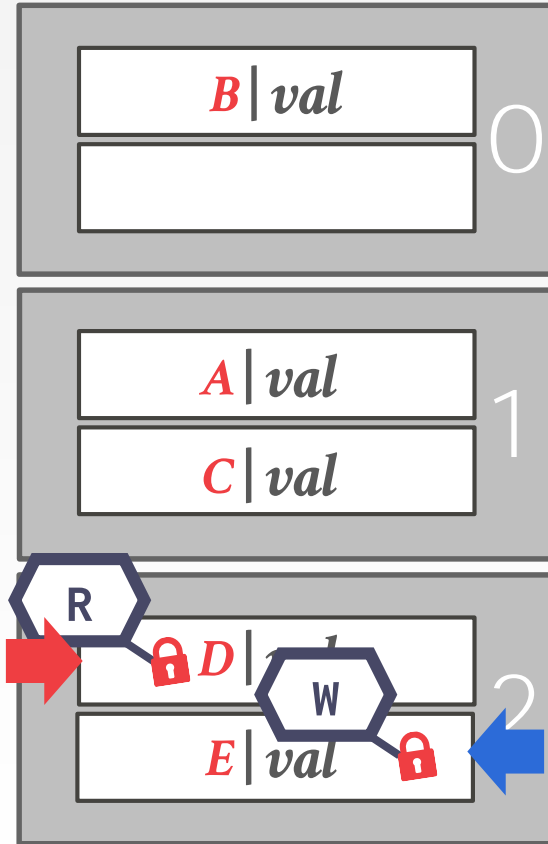

$T_2$ : Insert E  
*hash(E)*



# B+ TREE CONCURRENCY CONTROL

---

We want to allow multiple threads to read and update a B+Tree at the same time.

We need to protect from two types of problems:

- Threads trying to modify the contents of a node at the same time.
- One thread traversing the tree while another thread splits/merges nodes.

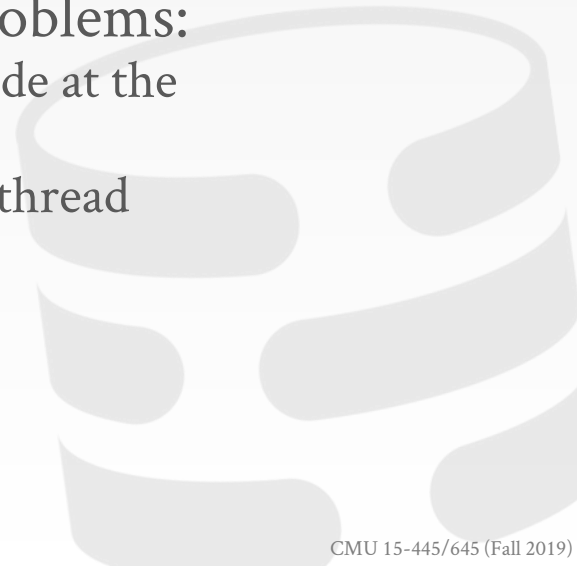

# B+TREE MULTI-THREADED EXAMPLE

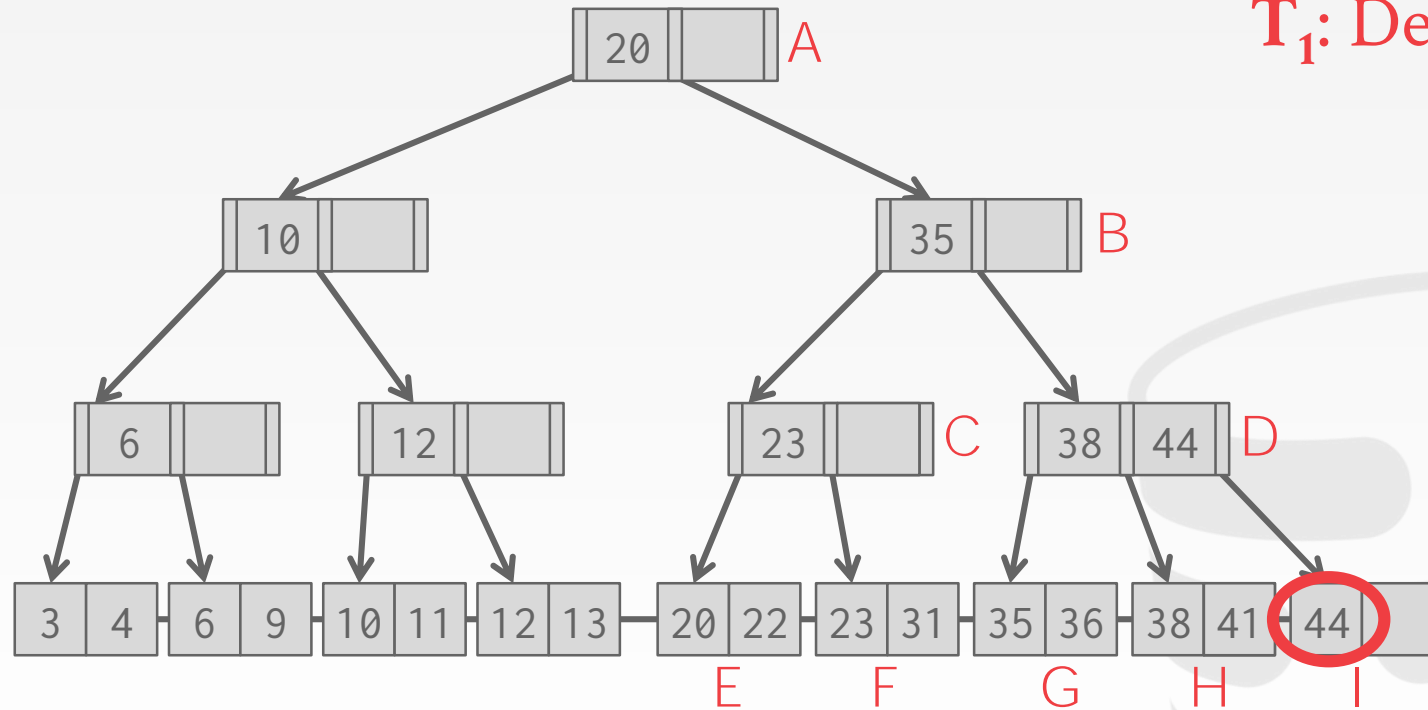

# B+TREE MULTI-THREADED EXAMPLE

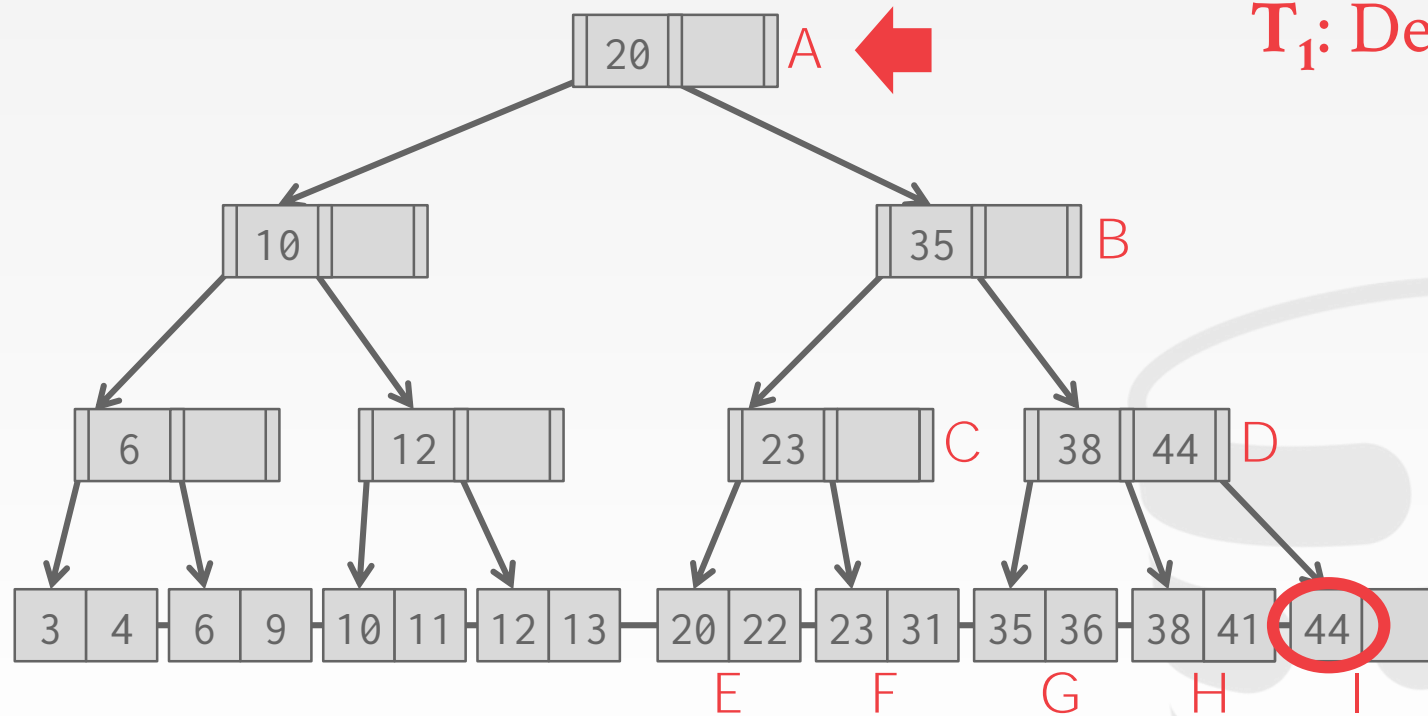



# B+TREE MULTI-THREADED EXAMPLE

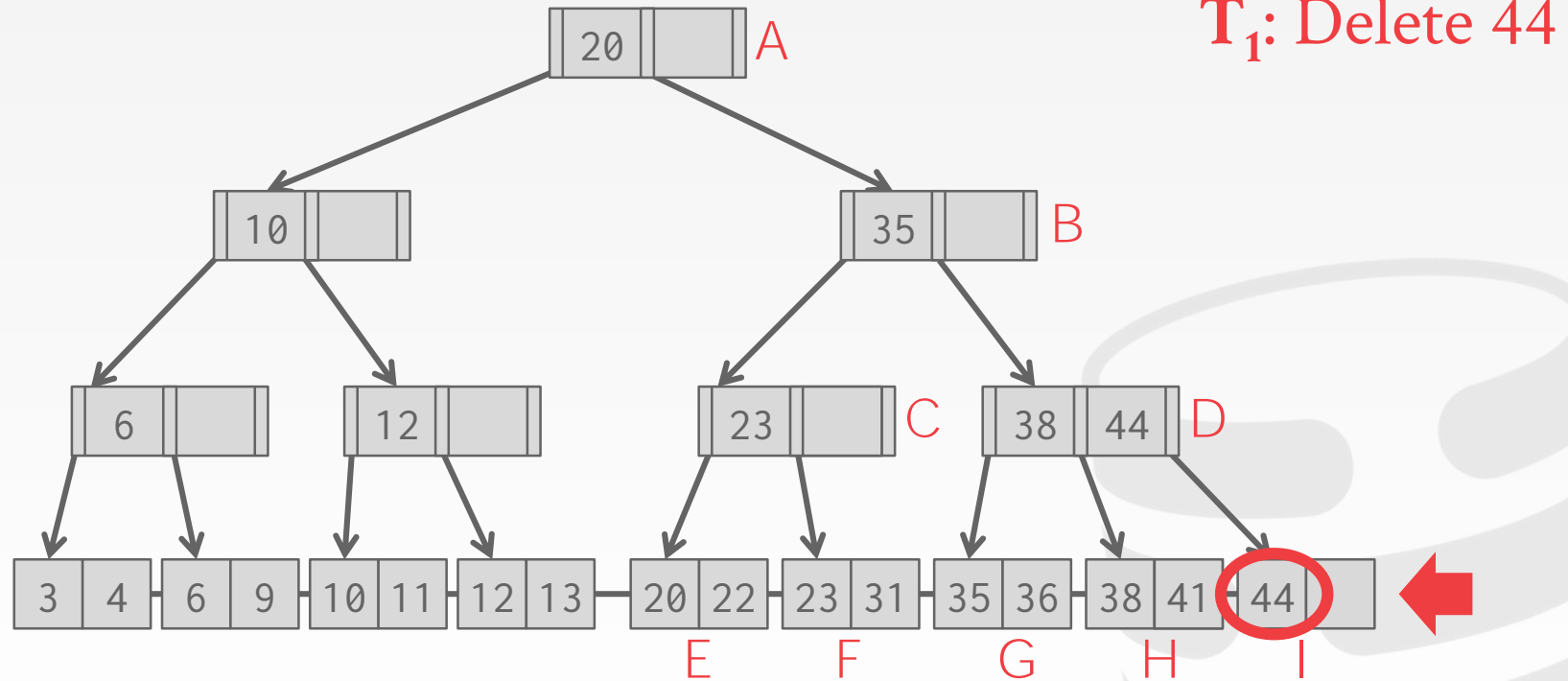

# B+TREE MULTI-THREADED EXAMPLE

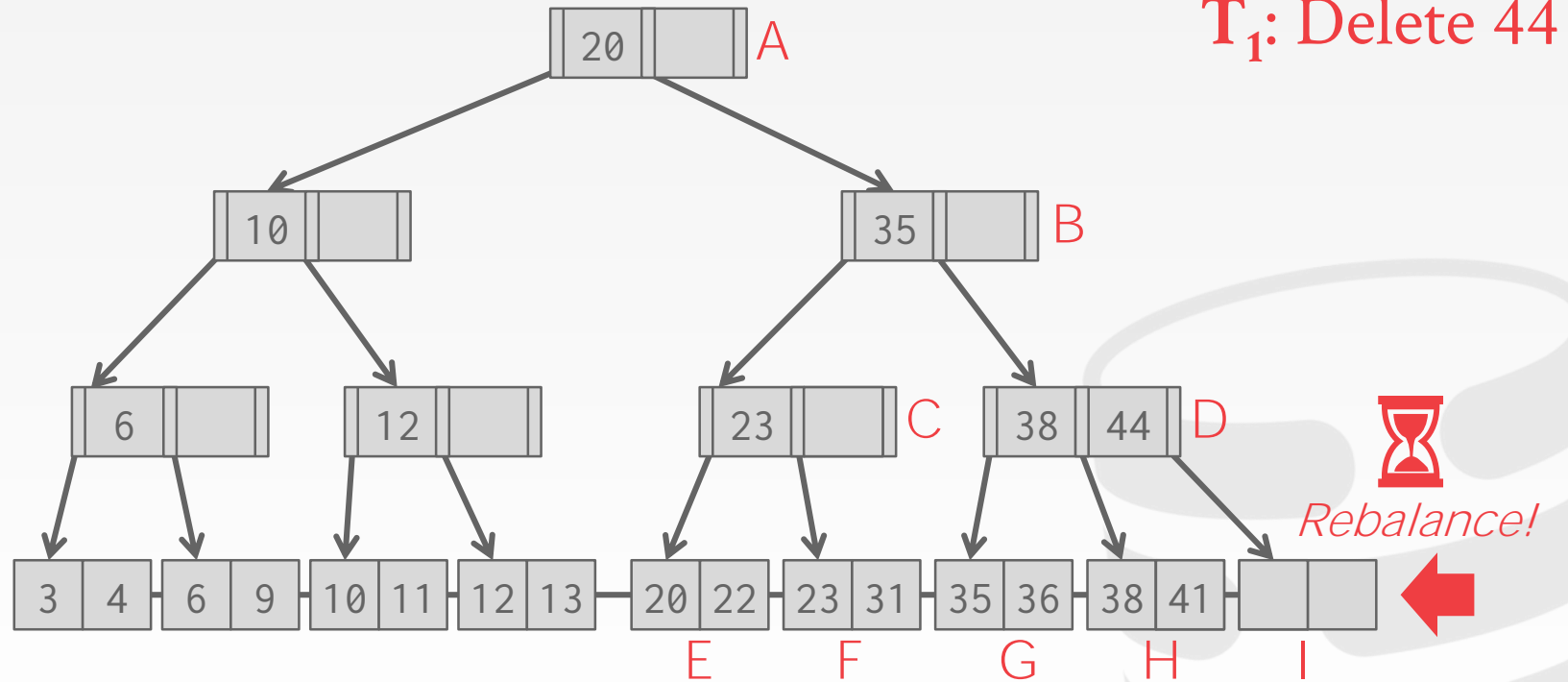

# B+TREE MULTI-THREADED EXAMPLE

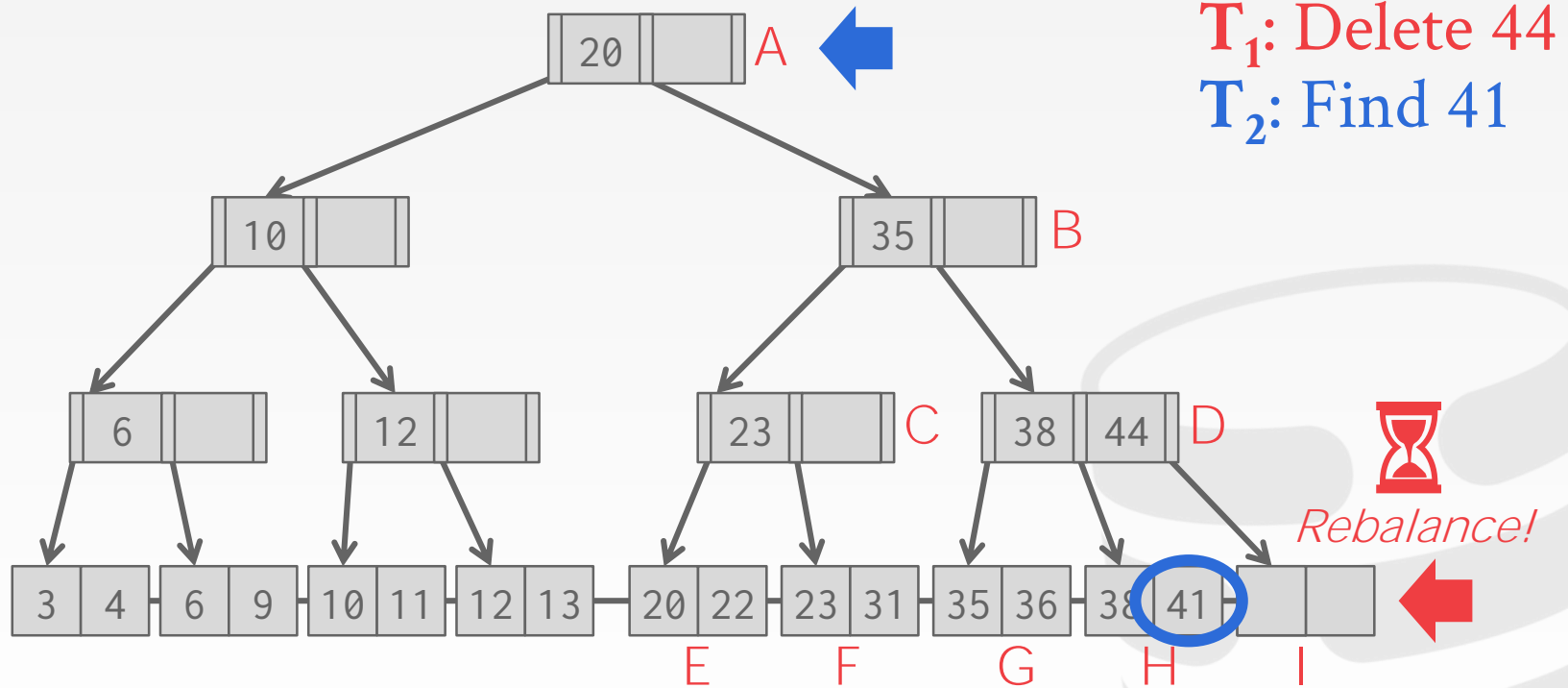

# B+TREE MULTI-THREADED EXAMPLE

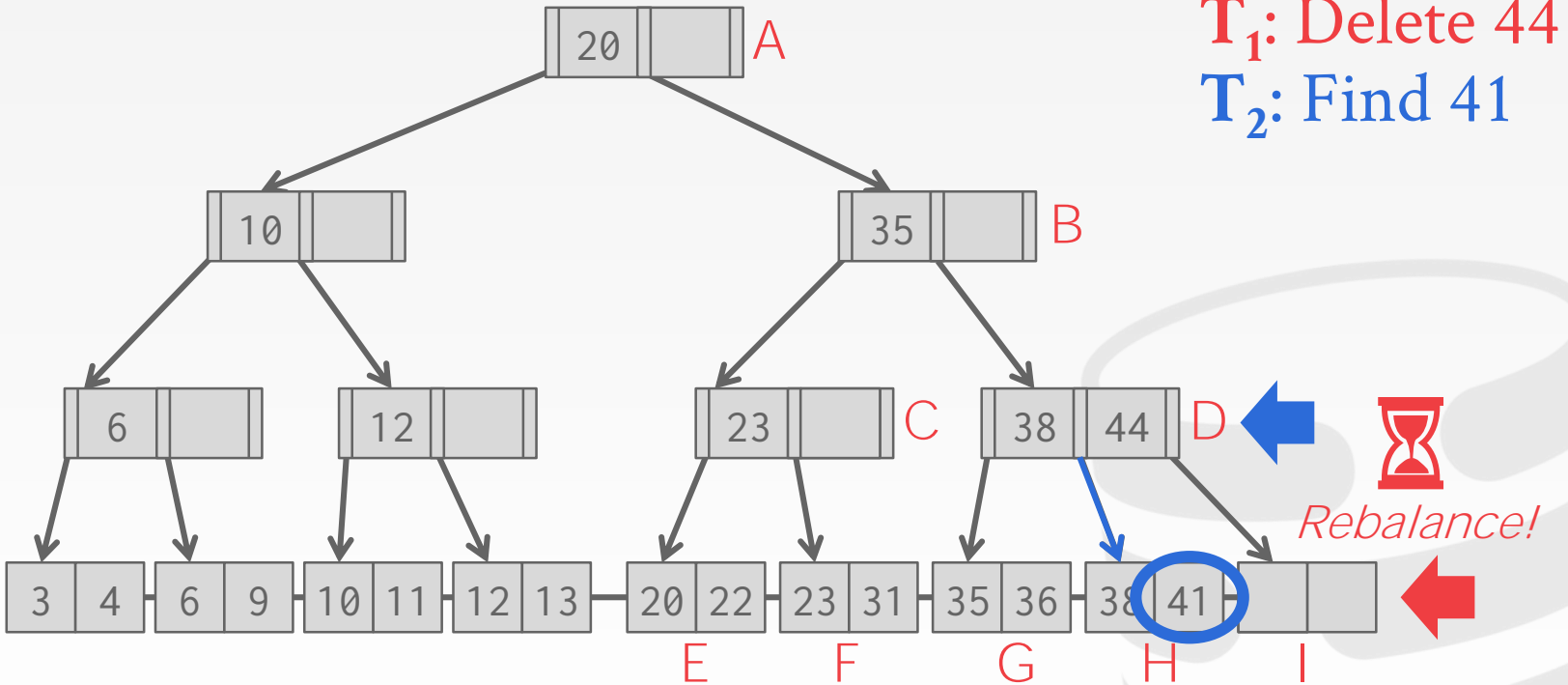

# B+TREE MULTI-THREADED EXAMPLE

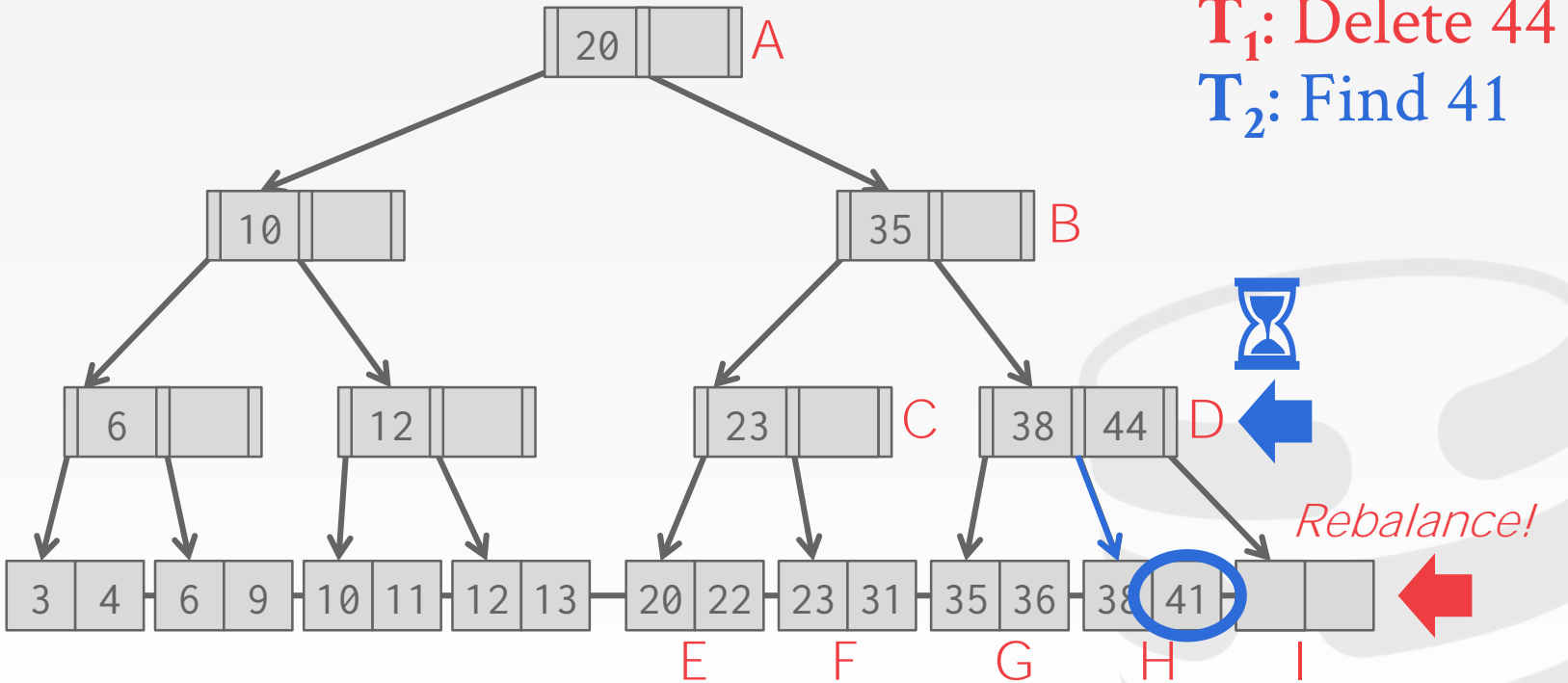

# B+TREE MULTI-THREADED EXAMPLE

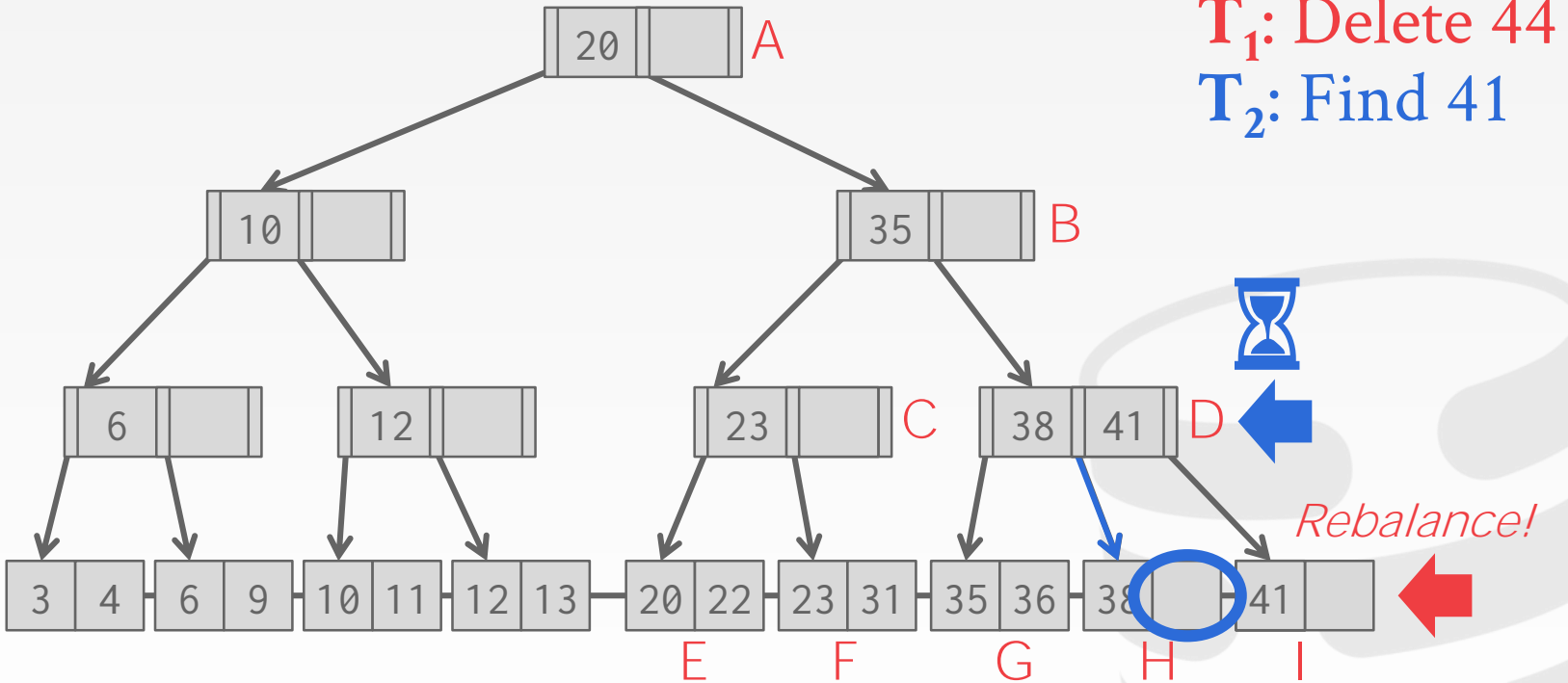

# B+TREE MULTI-THREADED EXAMPLE

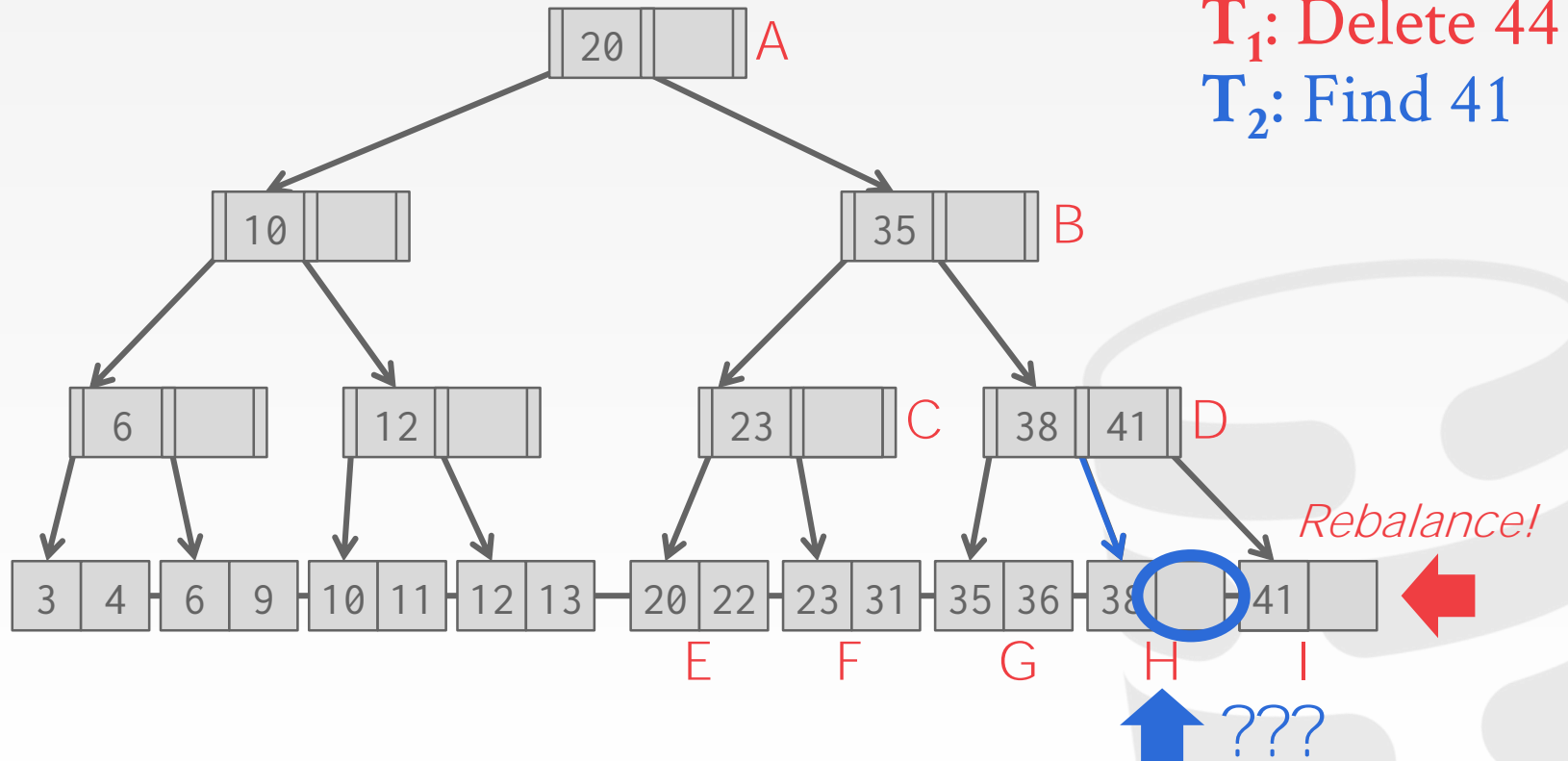

# LATCH CRABBING/COUPLING

---

Protocol to allow multiple threads to access/modify B+Tree at the same time.

Basic Idea:

- Get latch for parent.
- Get latch for child
- Release latch for parent if “safe”.

A **safe node** is one that will not split or merge when updated.

- Not full (on insertion)
- More than half-full (on deletion)



# LATCH CRABBING/COUPLING

---

**Find:** Start at root and go down; repeatedly,

- Acquire **R** latch on child
- Then unlatch parent

**Insert/Delete:** Start at root and go down, obtaining **W** latches as needed. Once child is latched, check if it is safe:

- If child is safe, release all latches on ancestors.

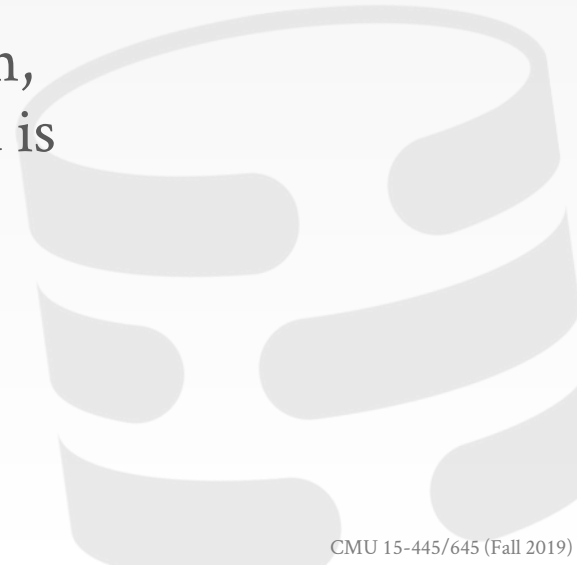

# EXAMPLE #1 – FIND 38

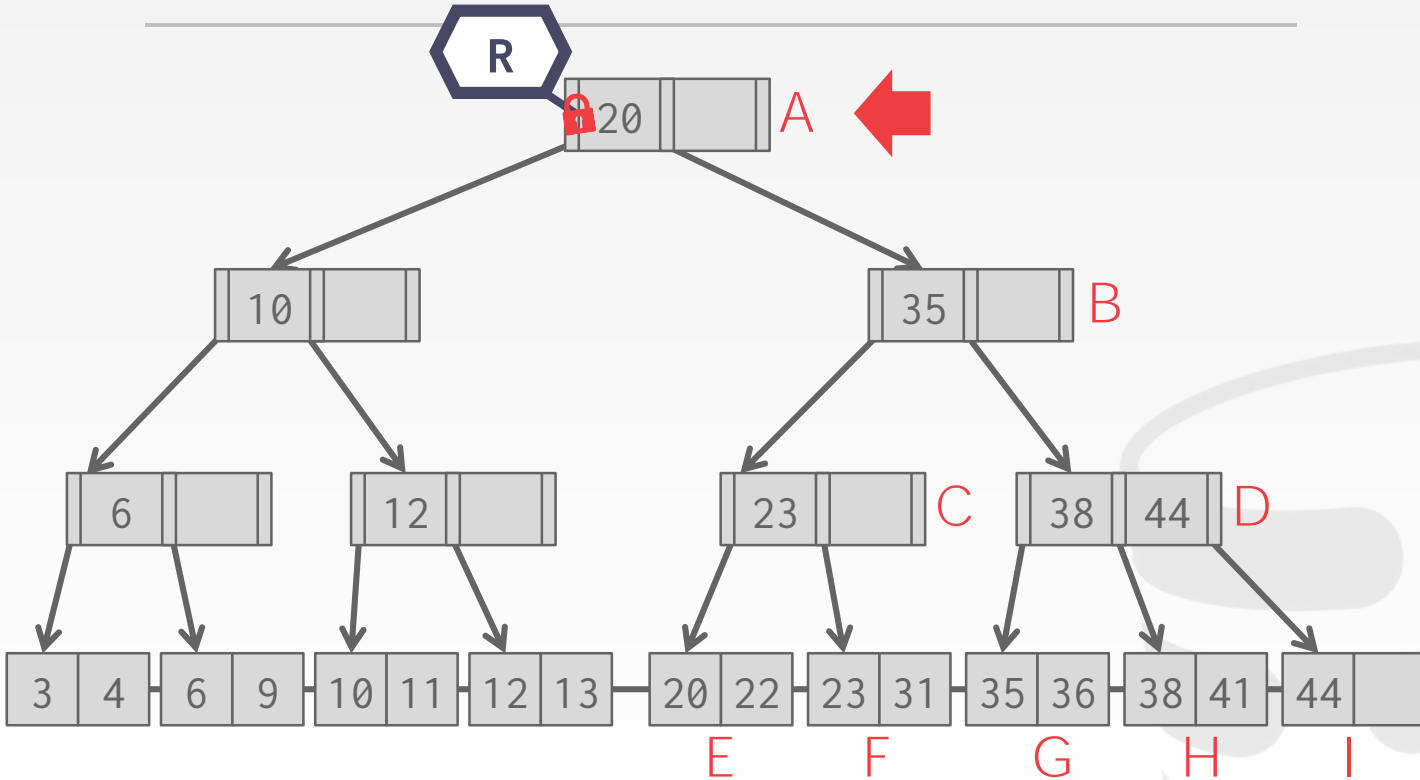

# EXAMPLE #1 – FIND 38

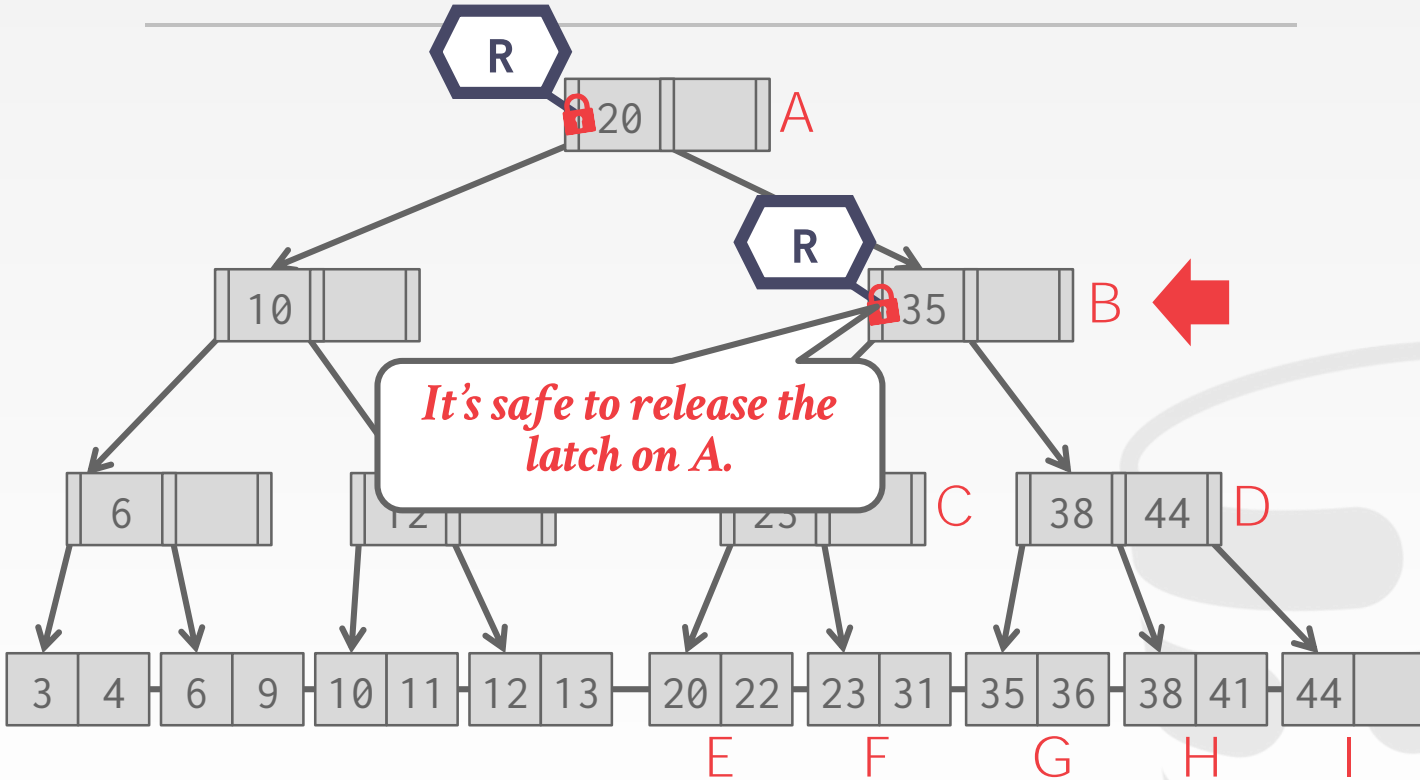

# EXAMPLE #1 – FIND 38

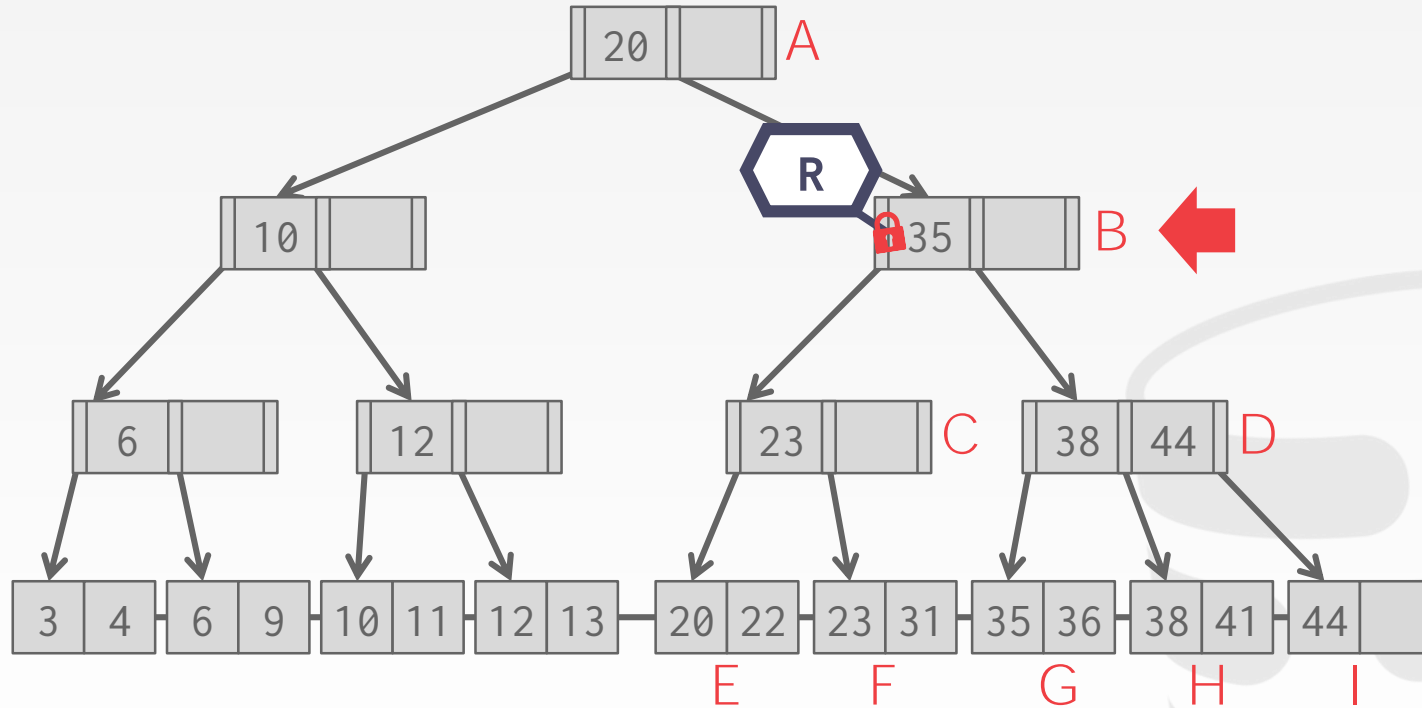

# EXAMPLE #1 – FIND 38

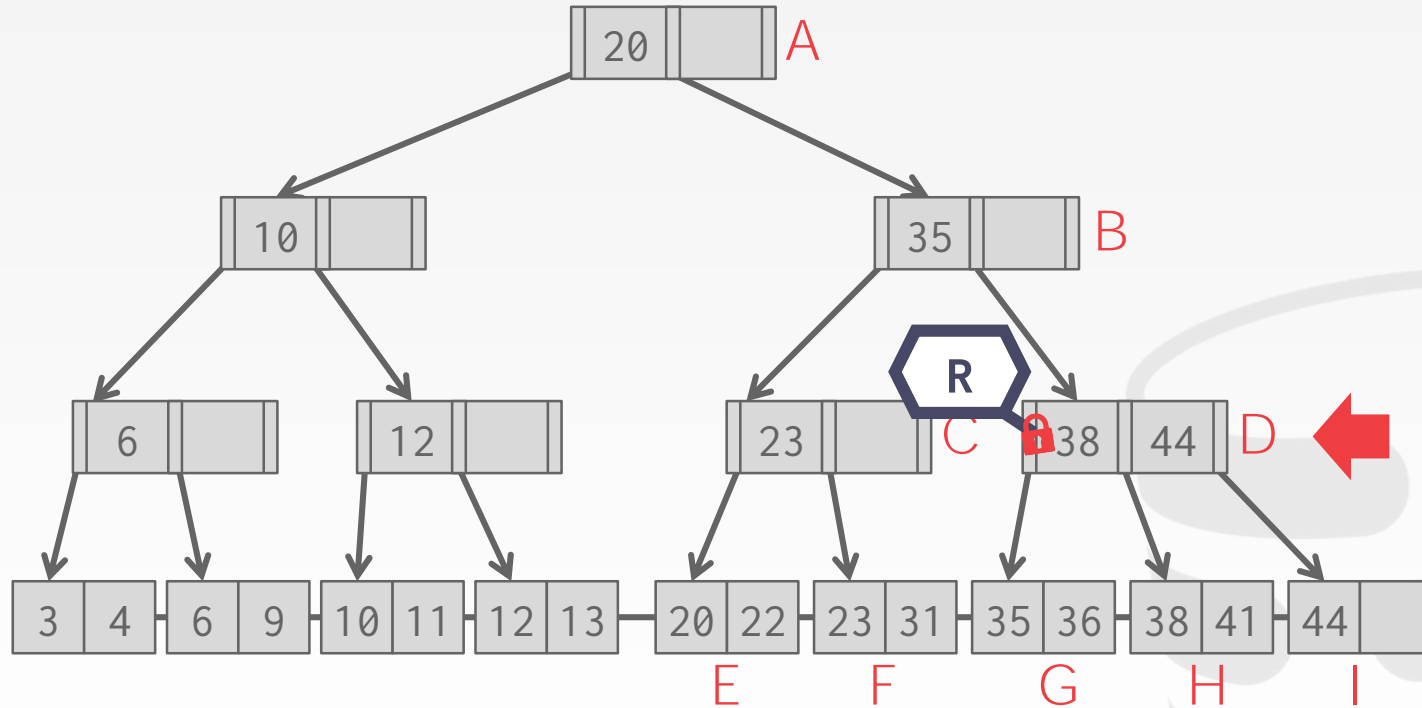

# EXAMPLE #1 – FIND 38

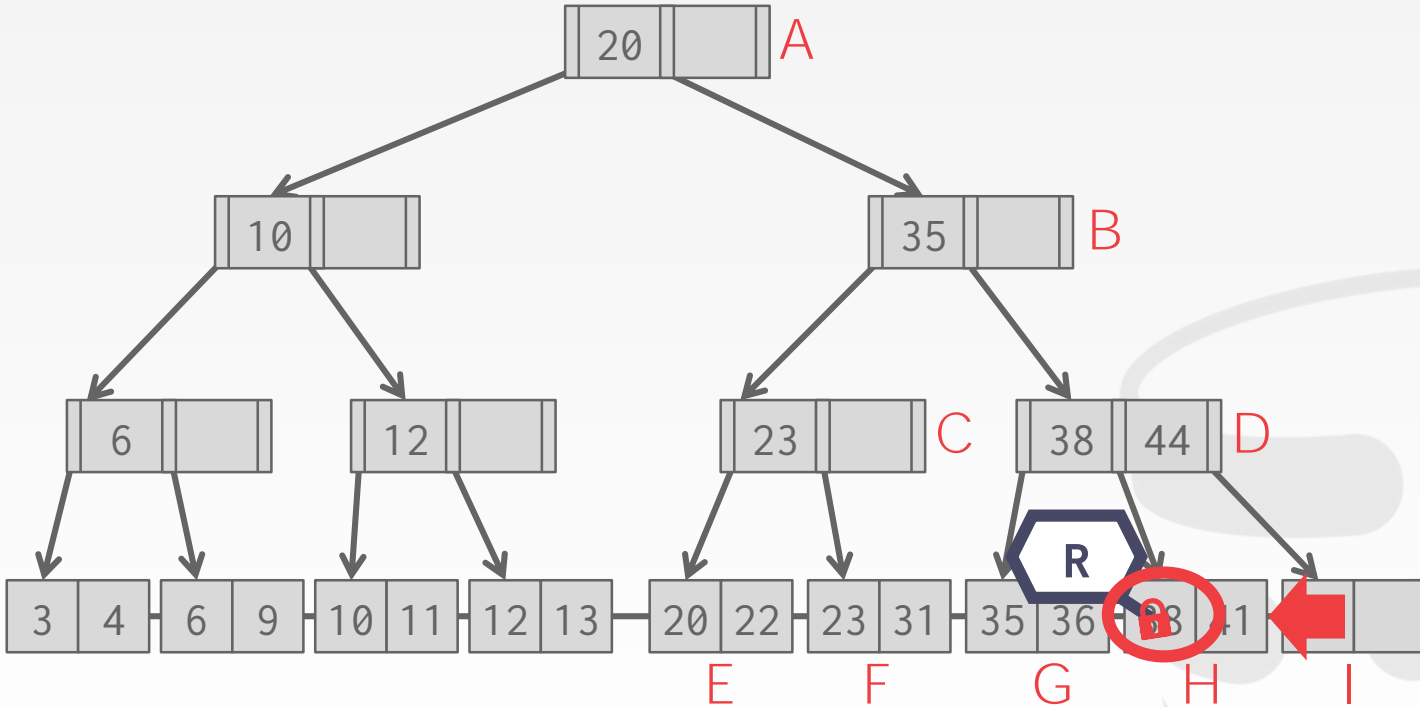

# EXAMPLE #1 – FIND 38

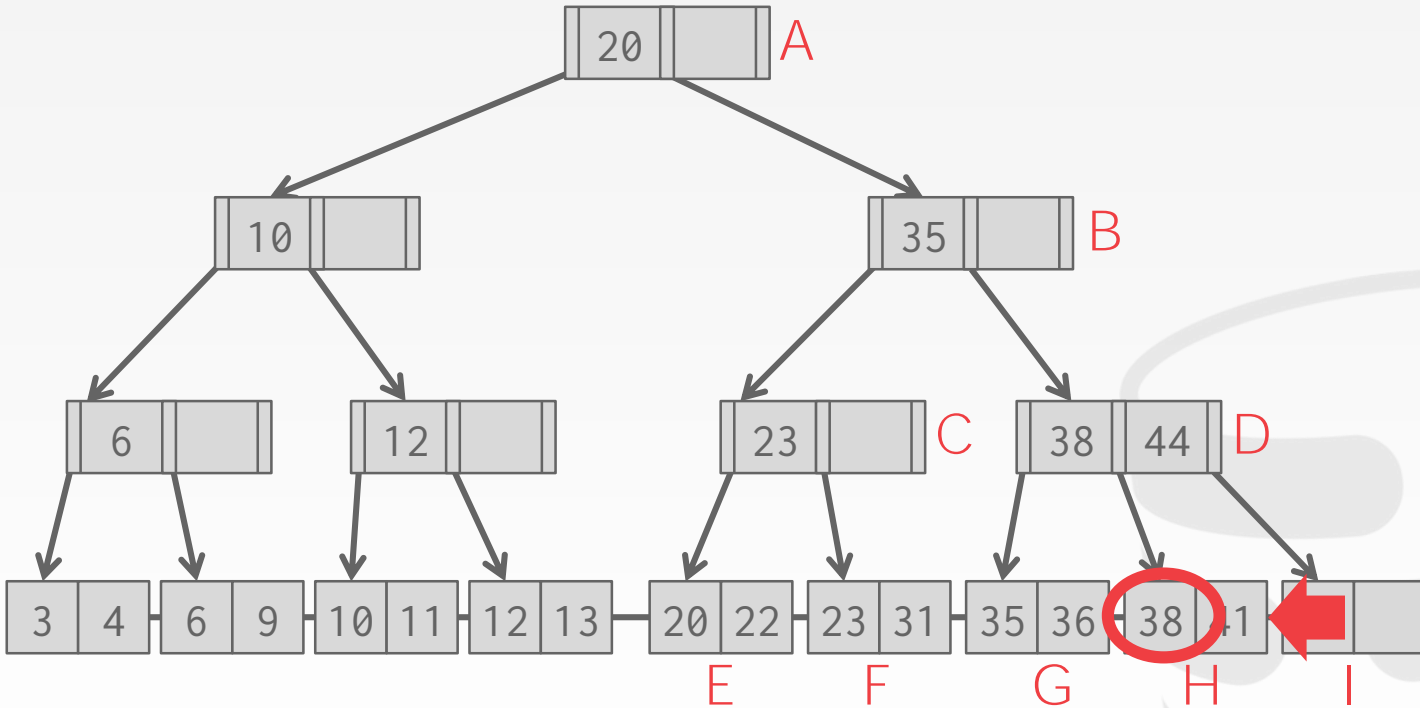

# EXAMPLE #2 – DELETE 38

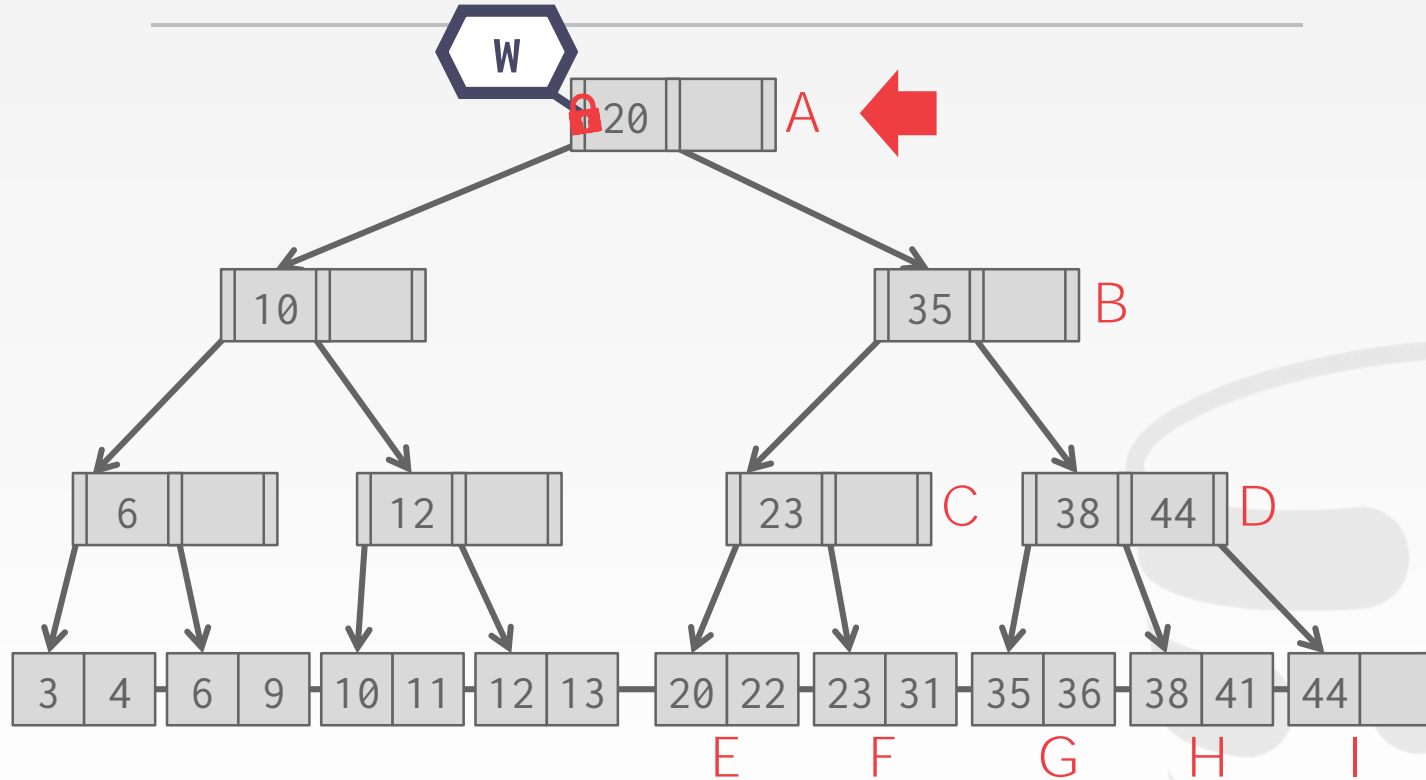



# EXAMPLE #2 – DELETE 38

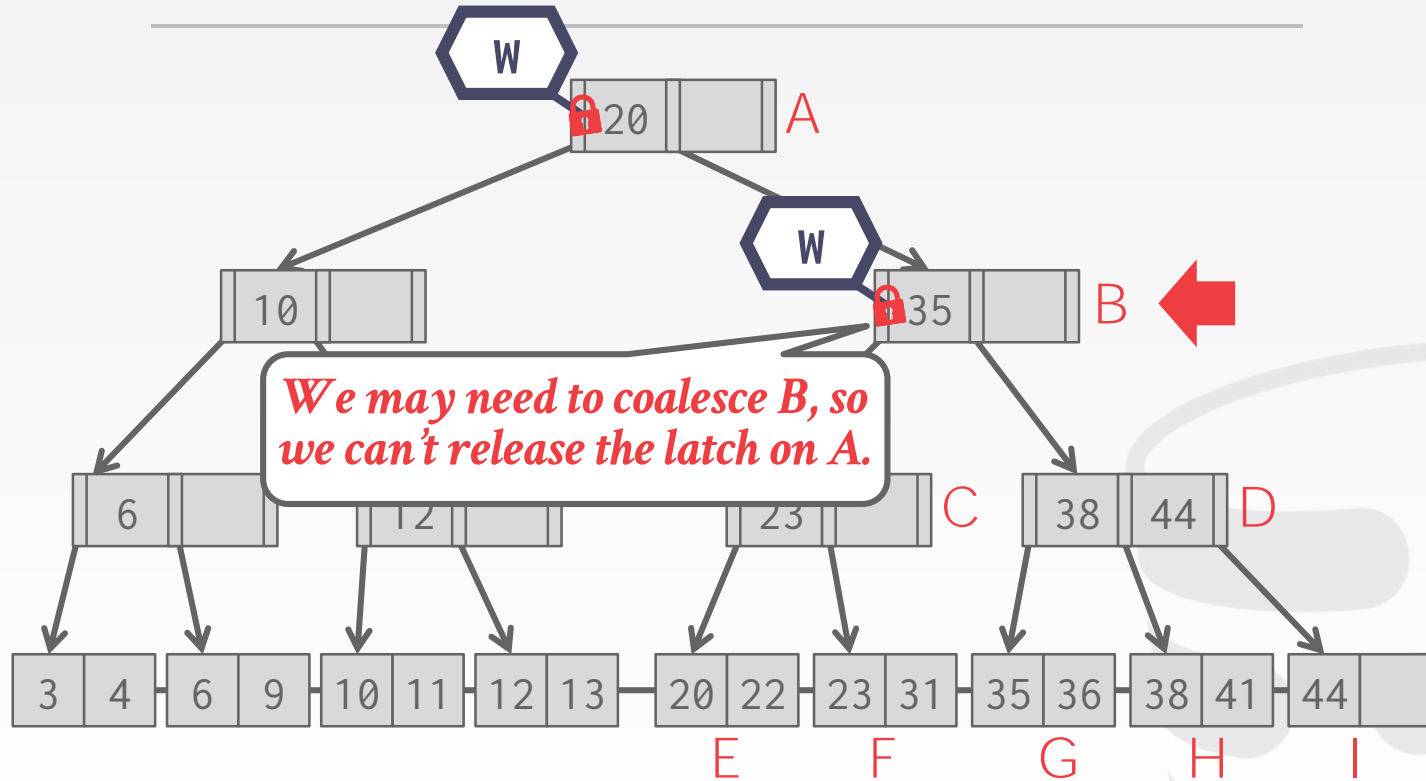

# EXAMPLE #2 – DELETE 38

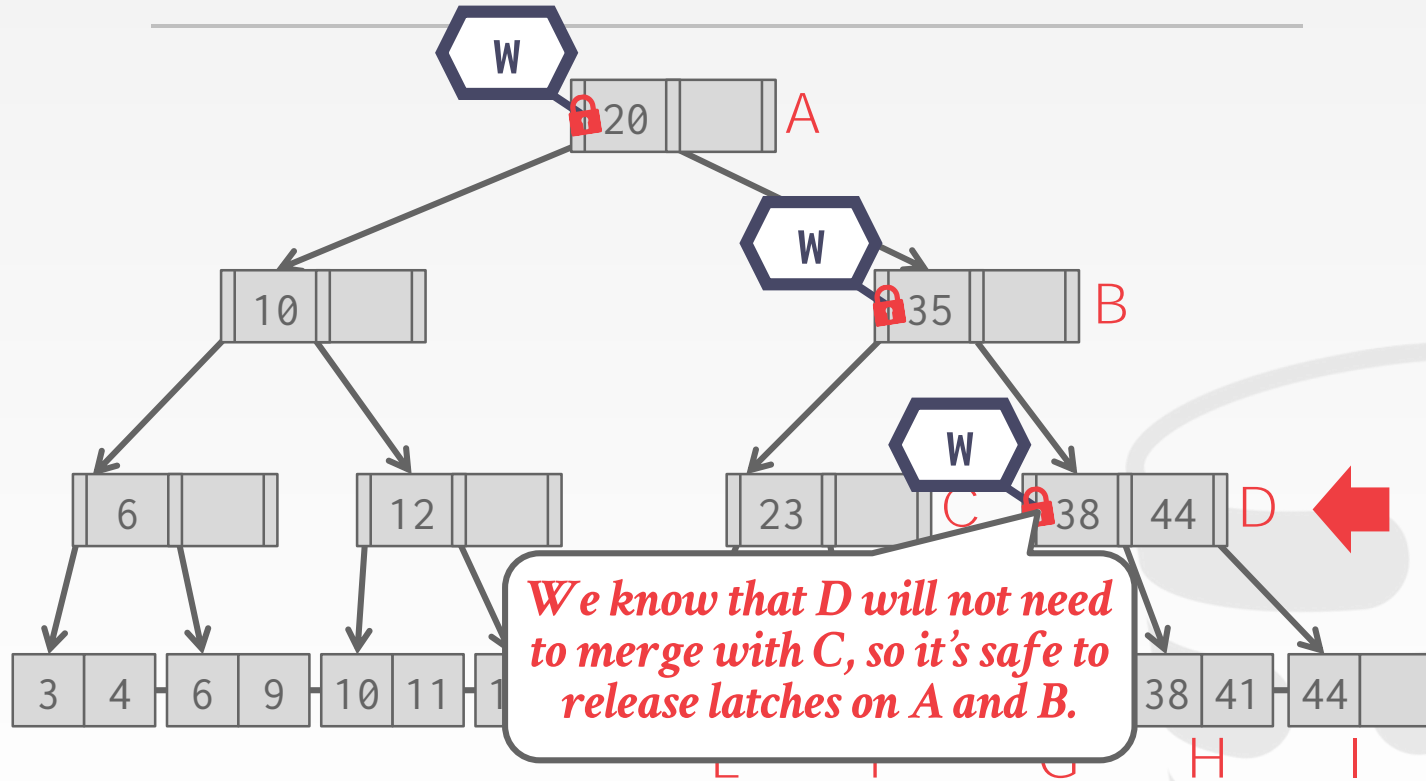

# EXAMPLE #2 – DELETE 38

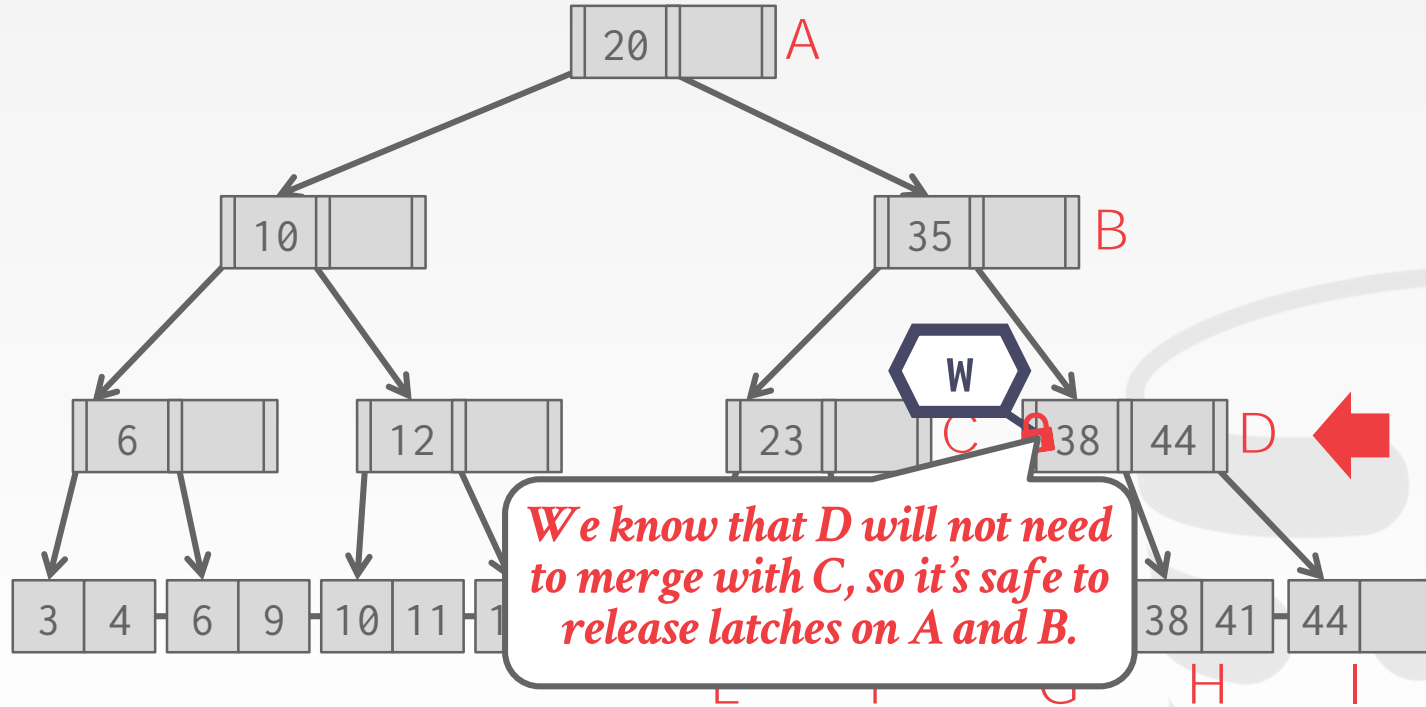

# EXAMPLE #2 – DELETE 38

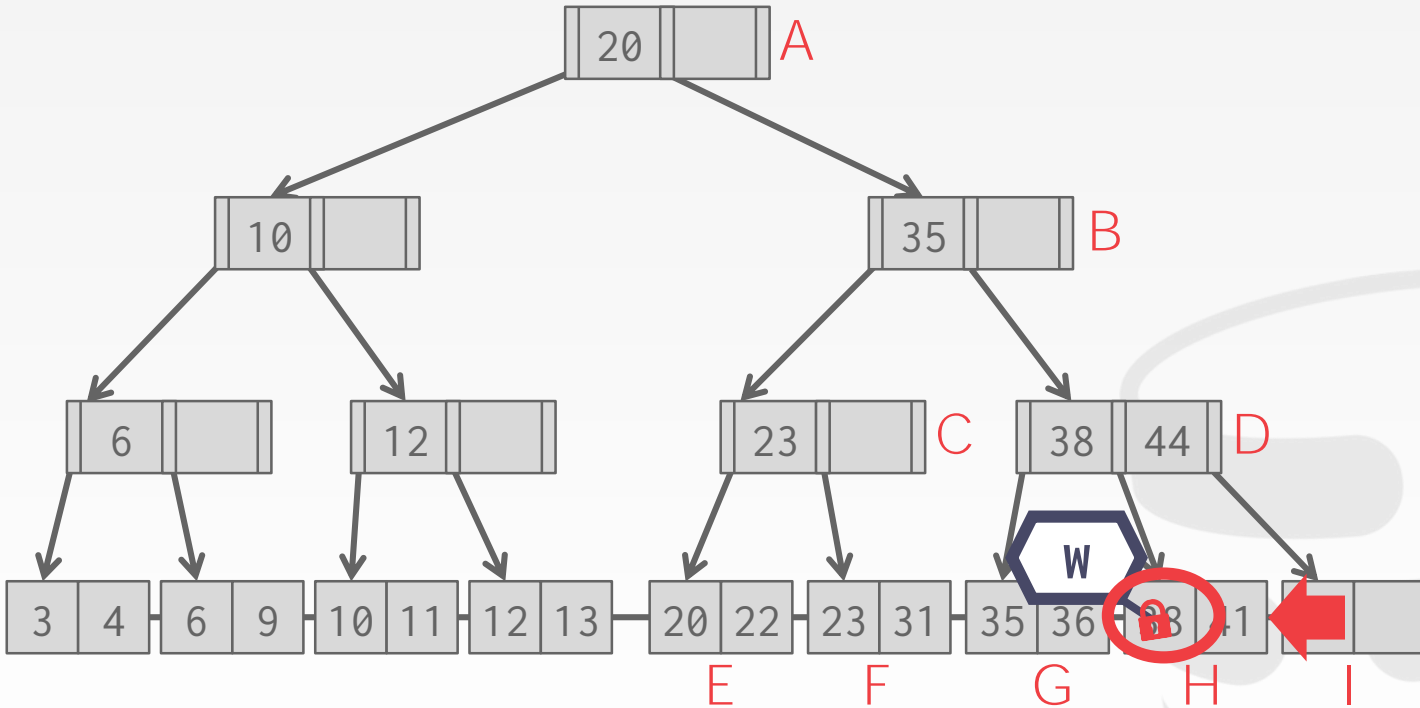

# EXAMPLE #2 – DELETE 38

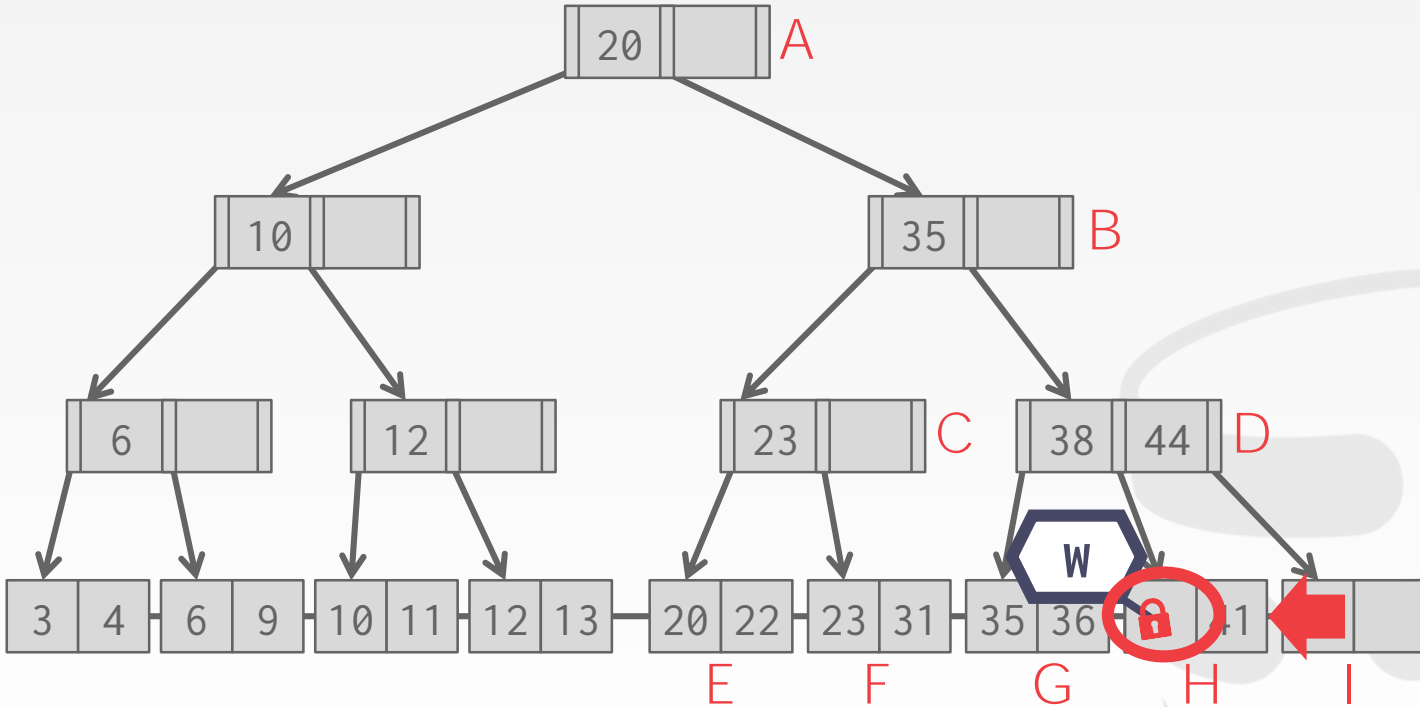

# EXAMPLE #3 – INSERT 45

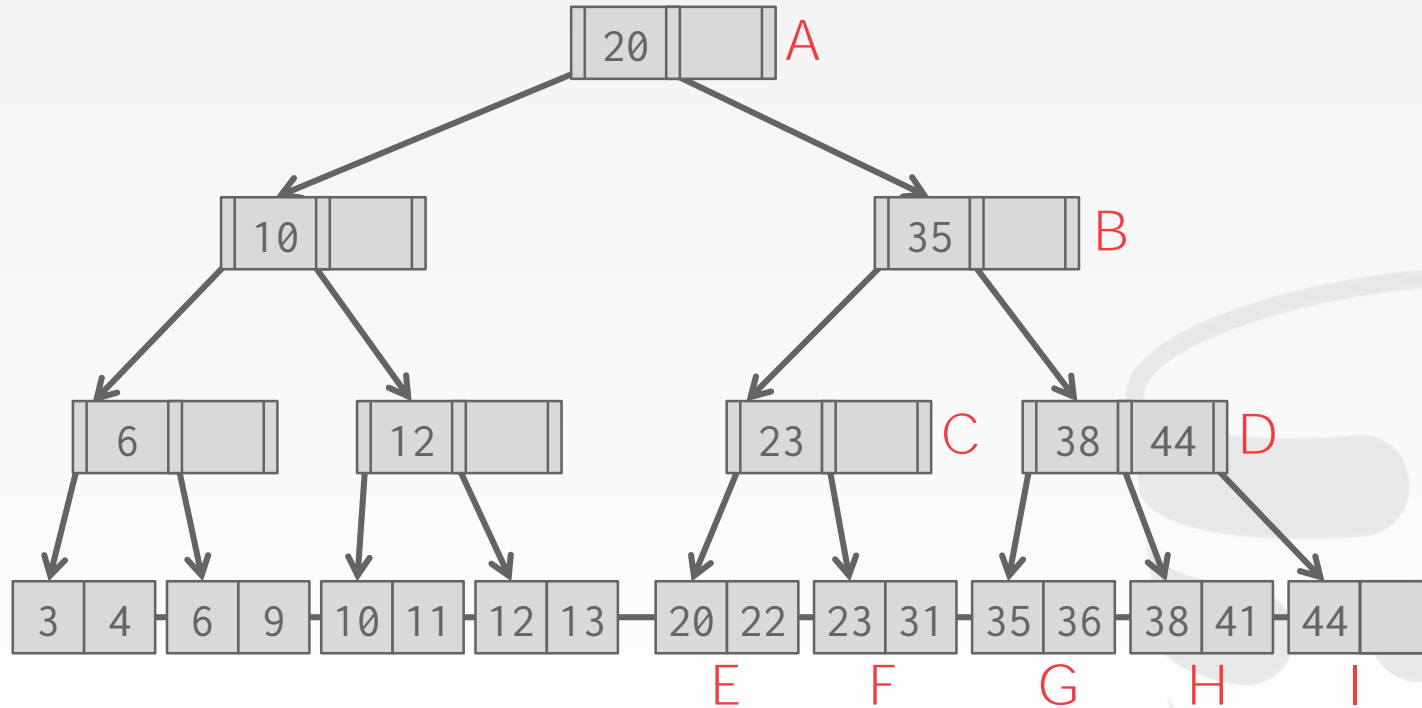

# EXAMPLE #3 – INSERT 45

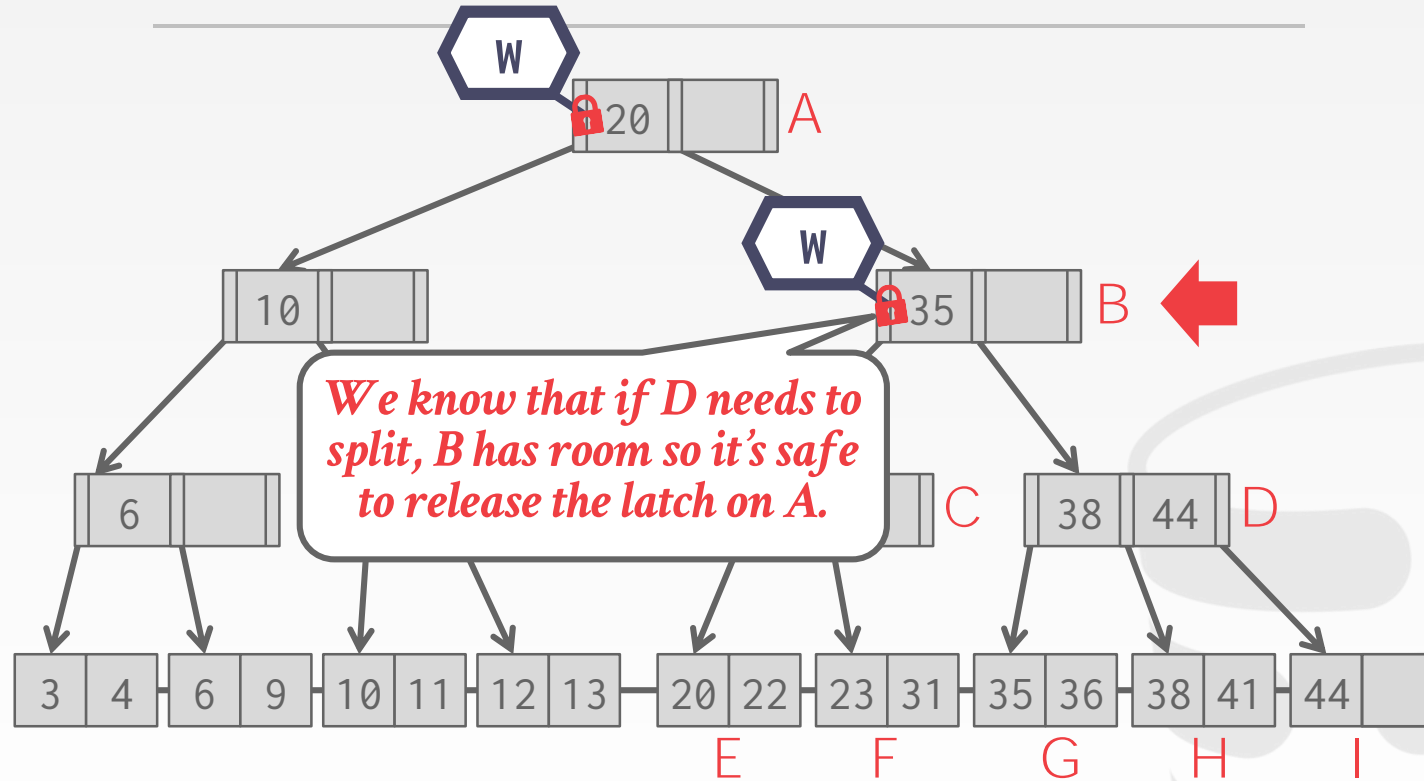

# EXAMPLE #3 – INSERT 45

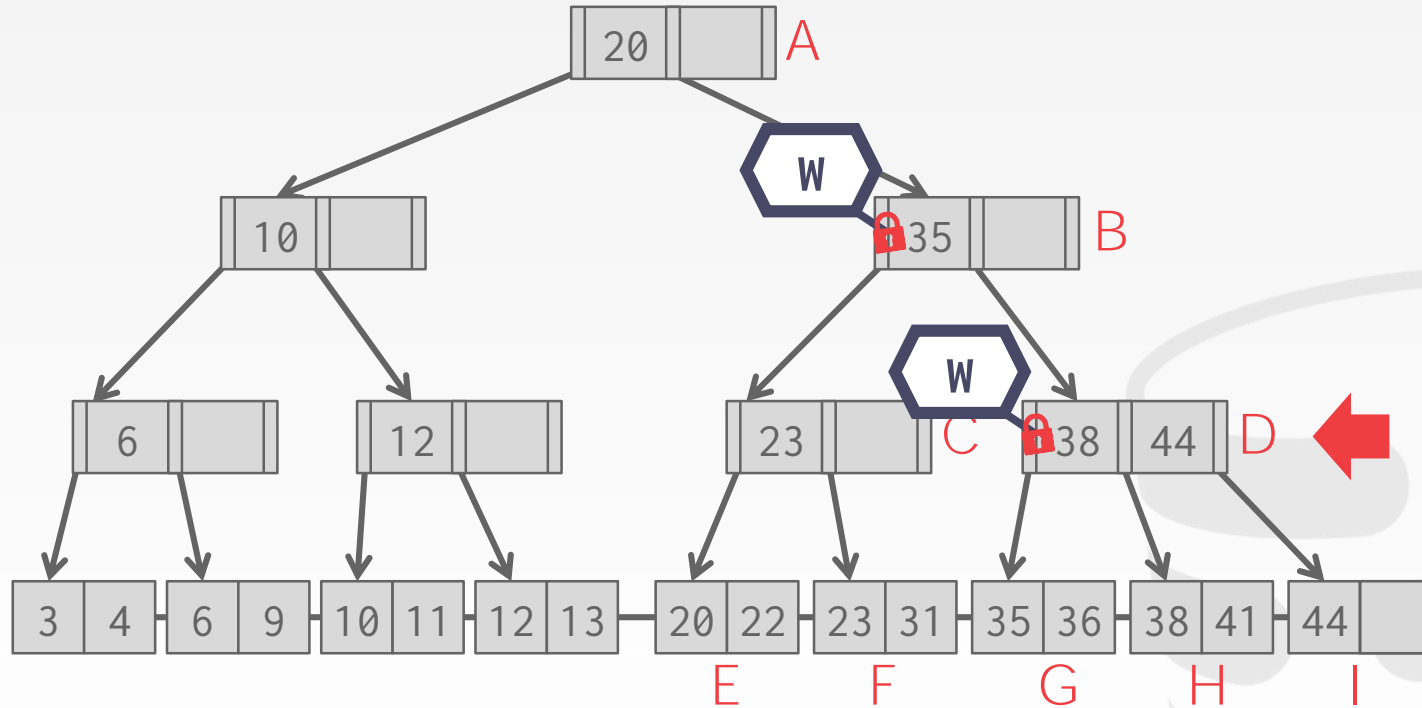



# EXAMPLE #3 – INSERT 45

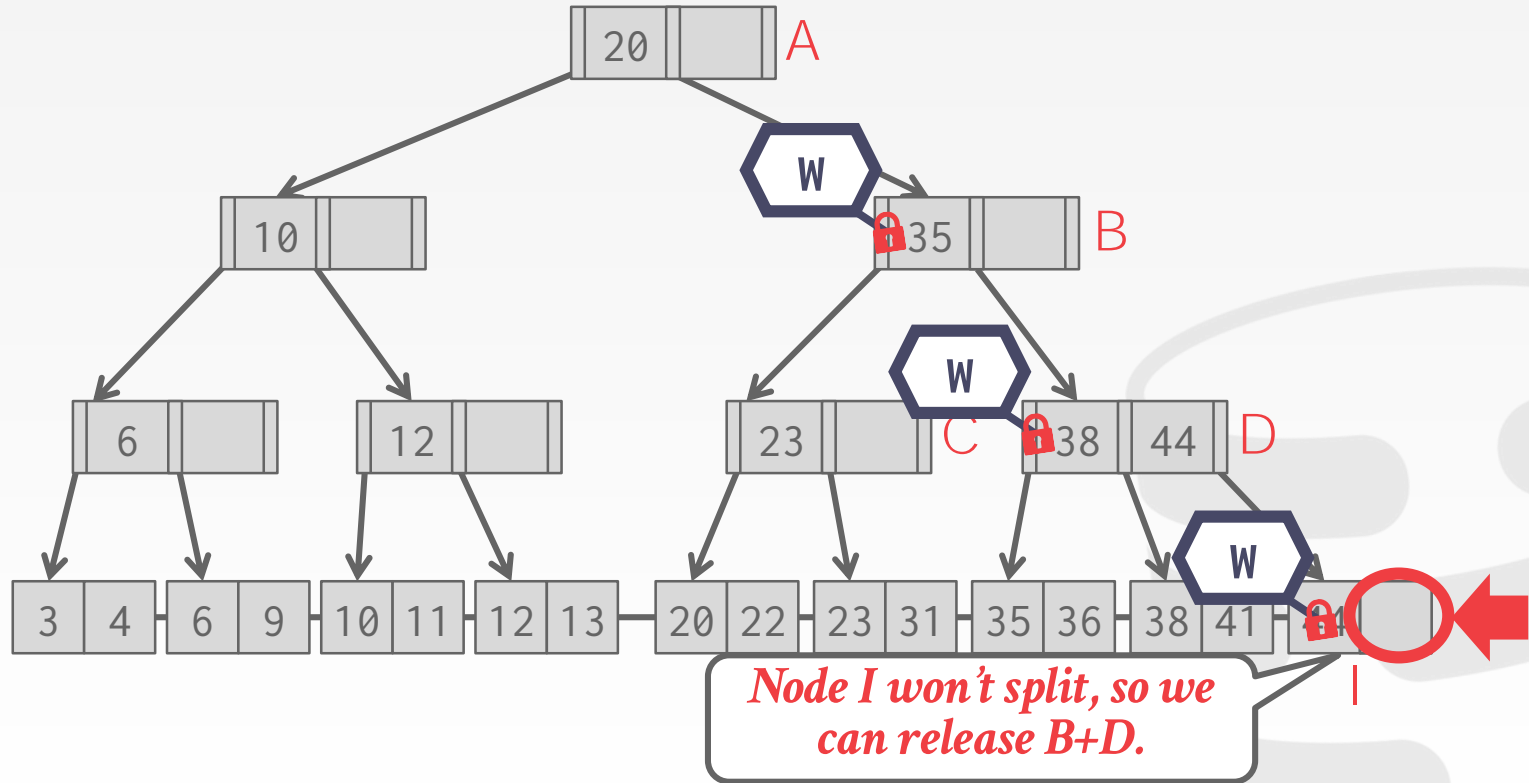

# EXAMPLE #3 – INSERT 45

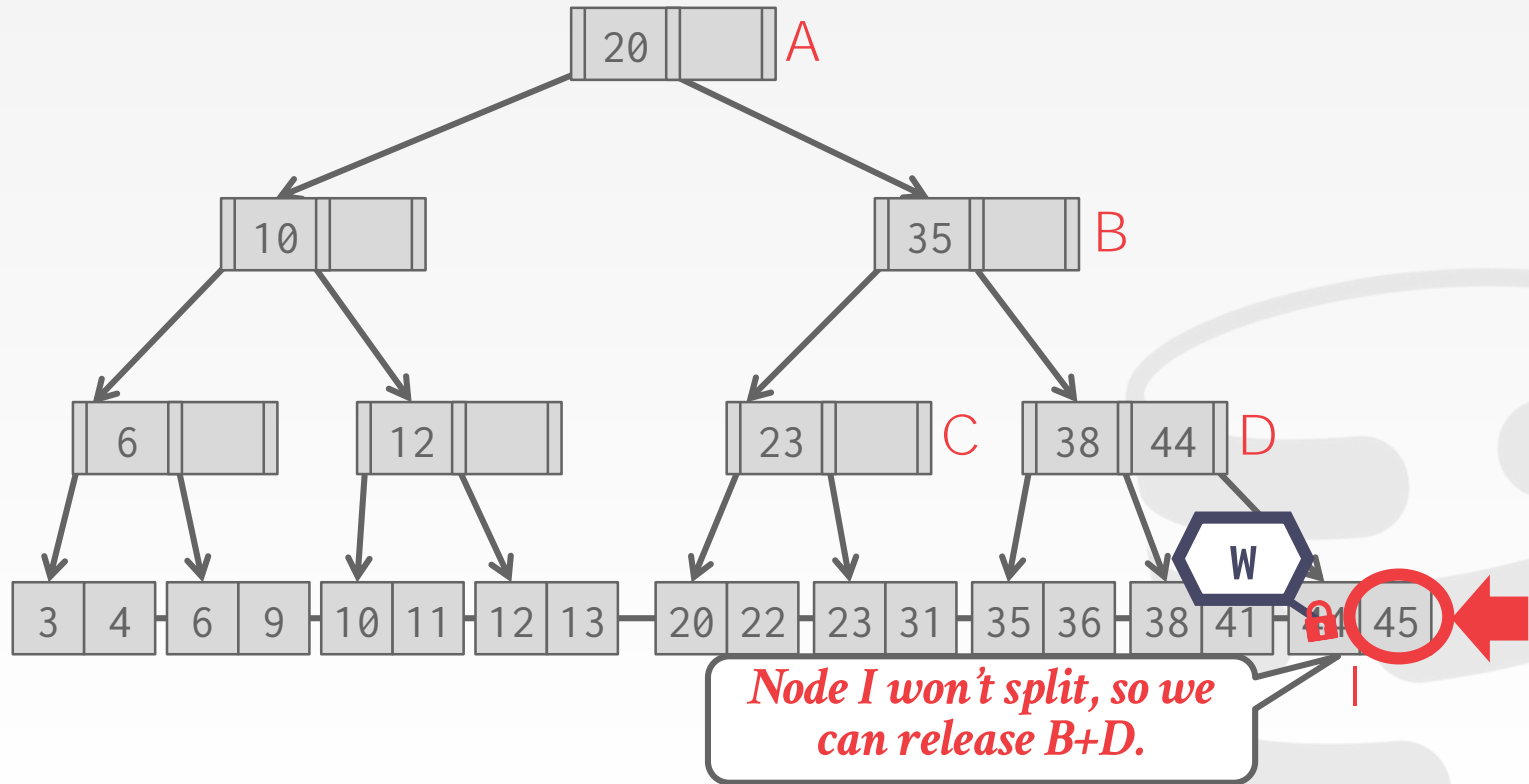

# EXAMPLE #4 – INSERT 25

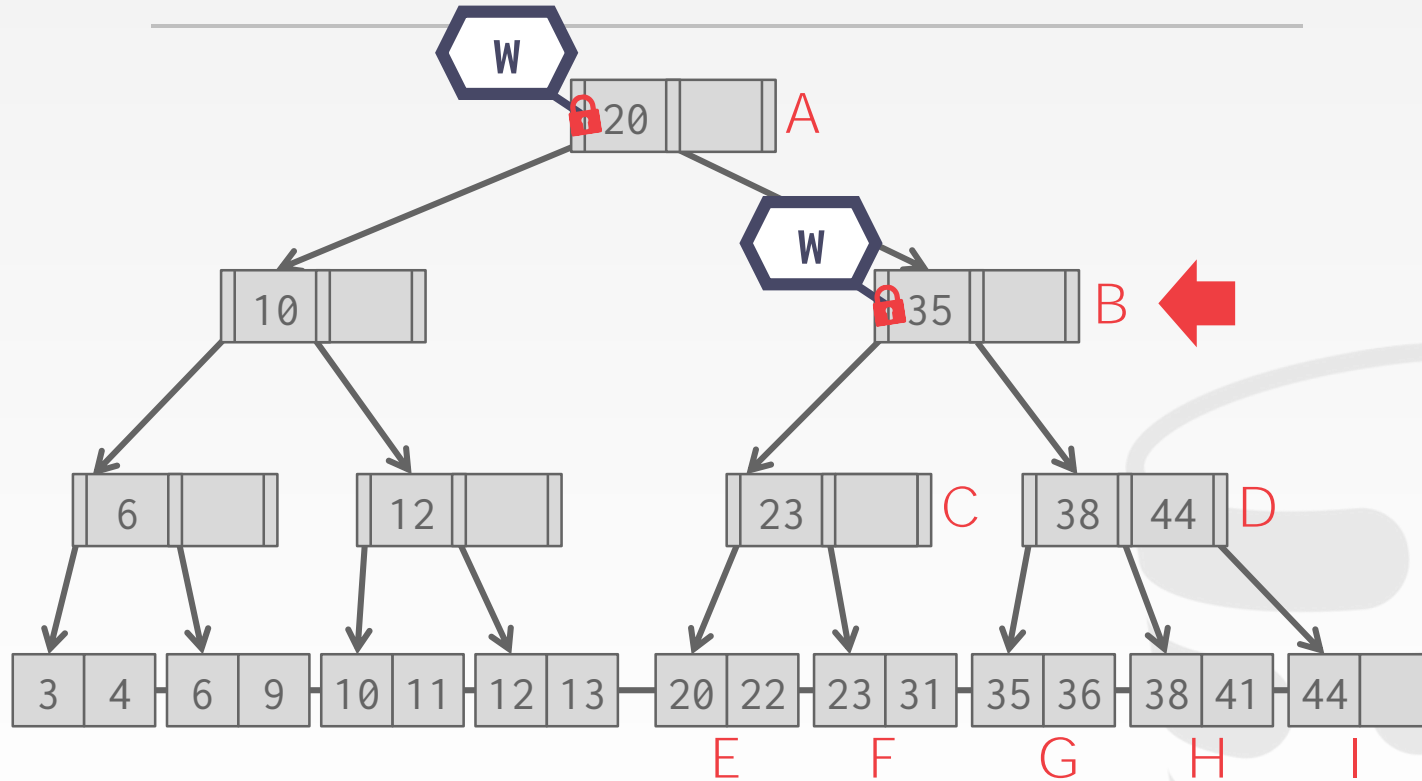

# EXAMPLE #4 – INSERT 25

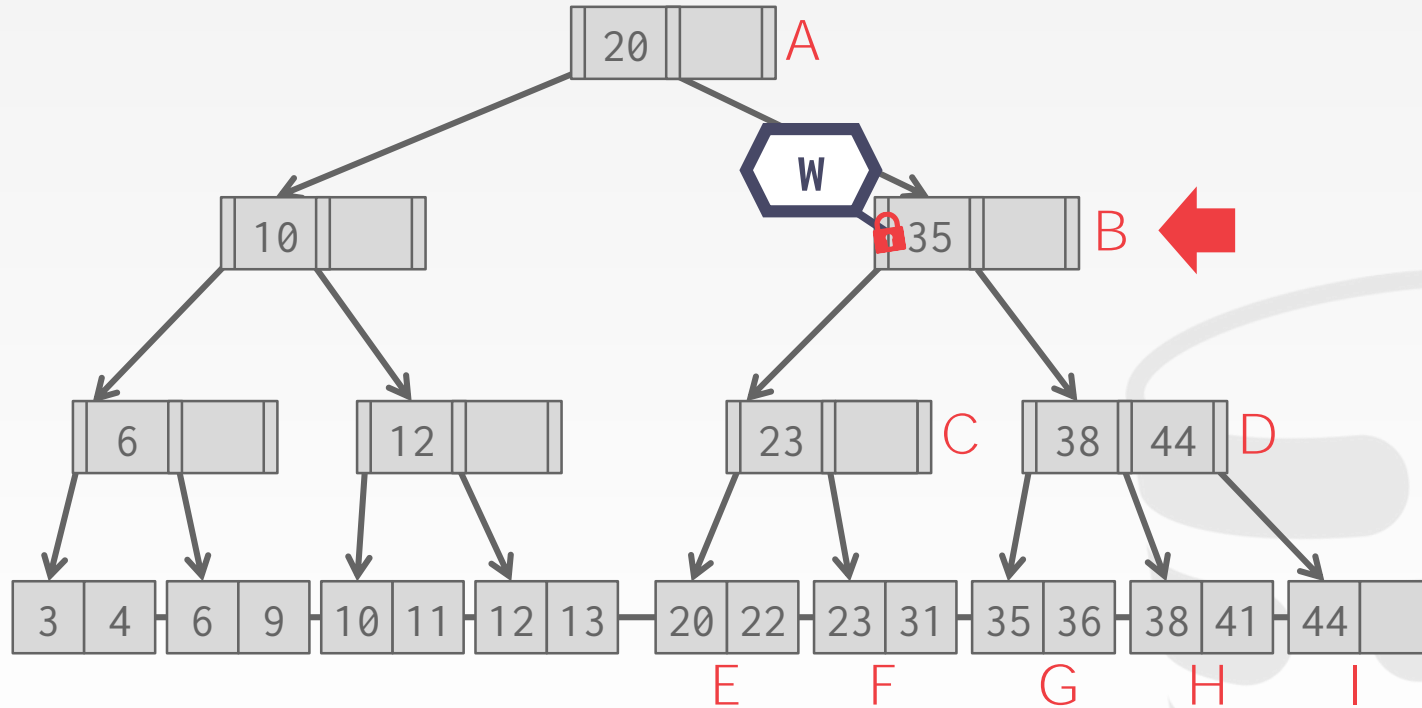

# EXAMPLE #4 – INSERT 25

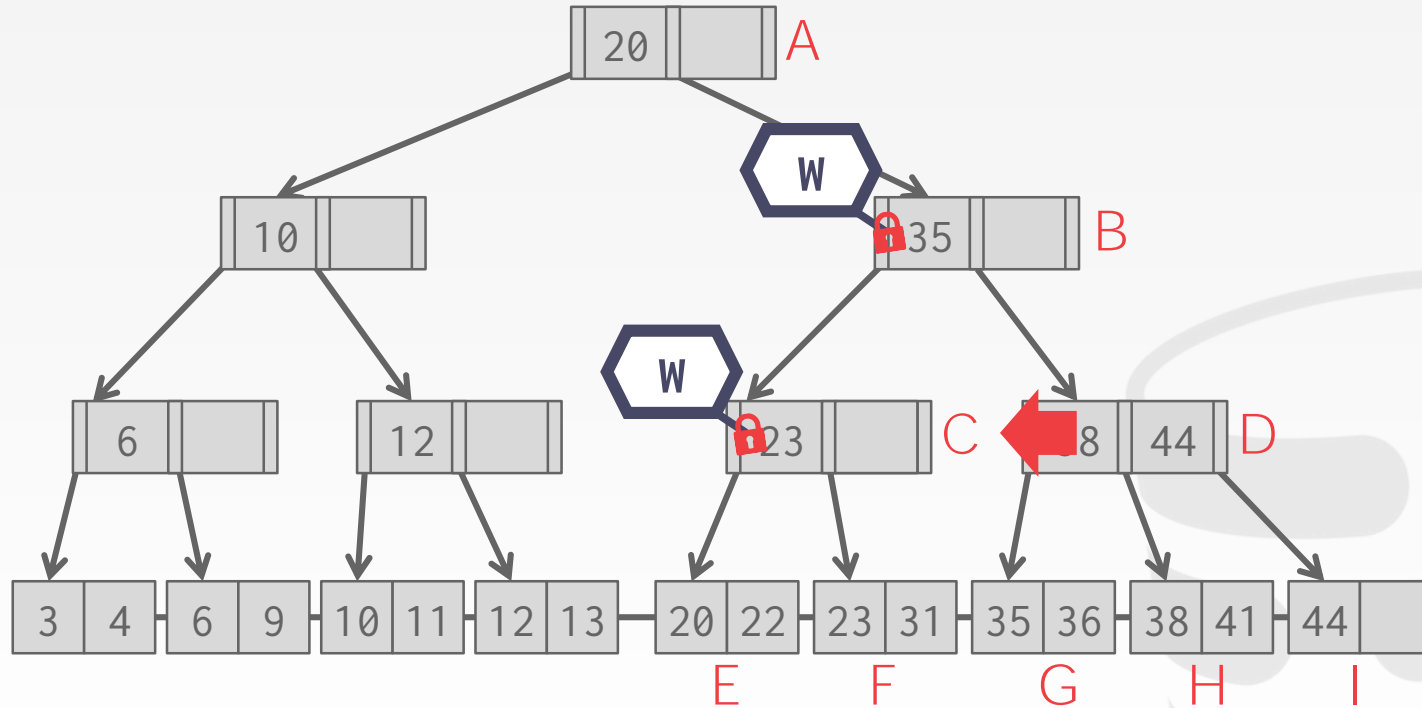

# EXAMPLE #4 – INSERT 25

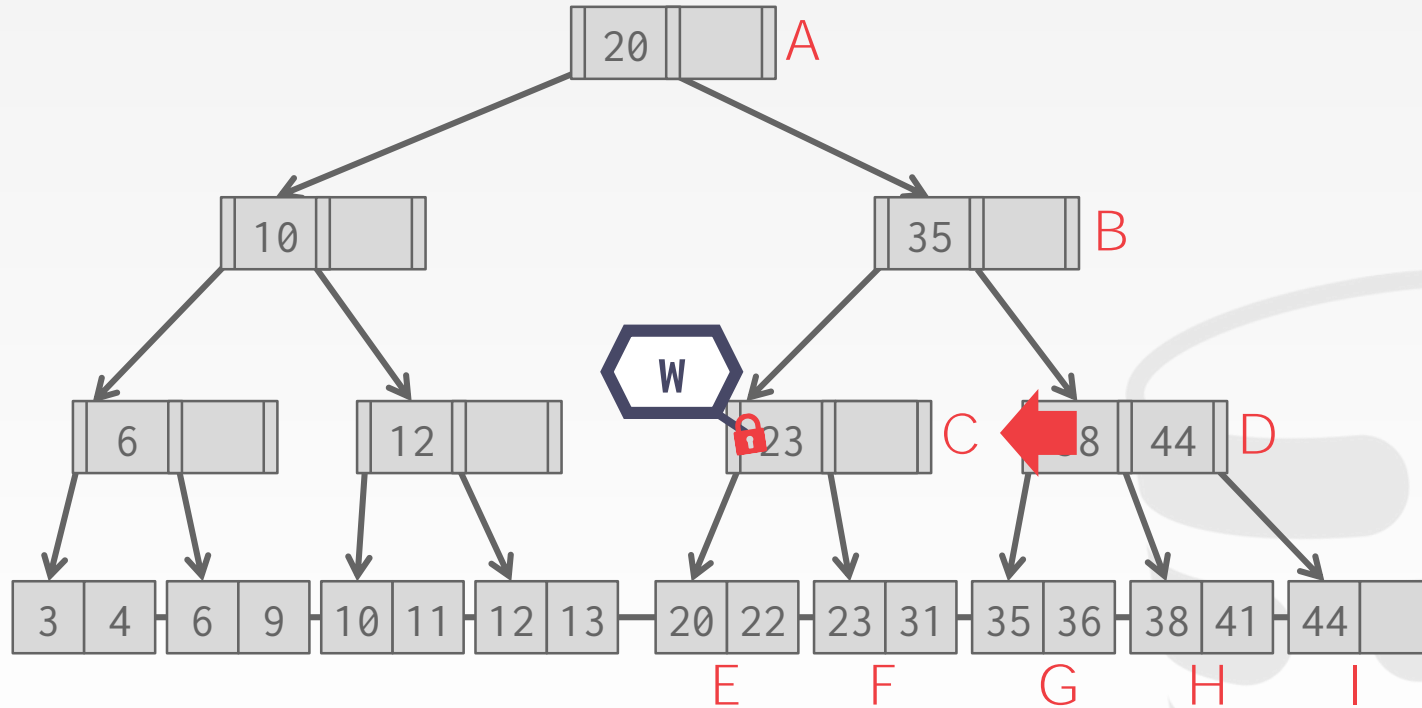

# EXAMPLE #4 – INSERT 25

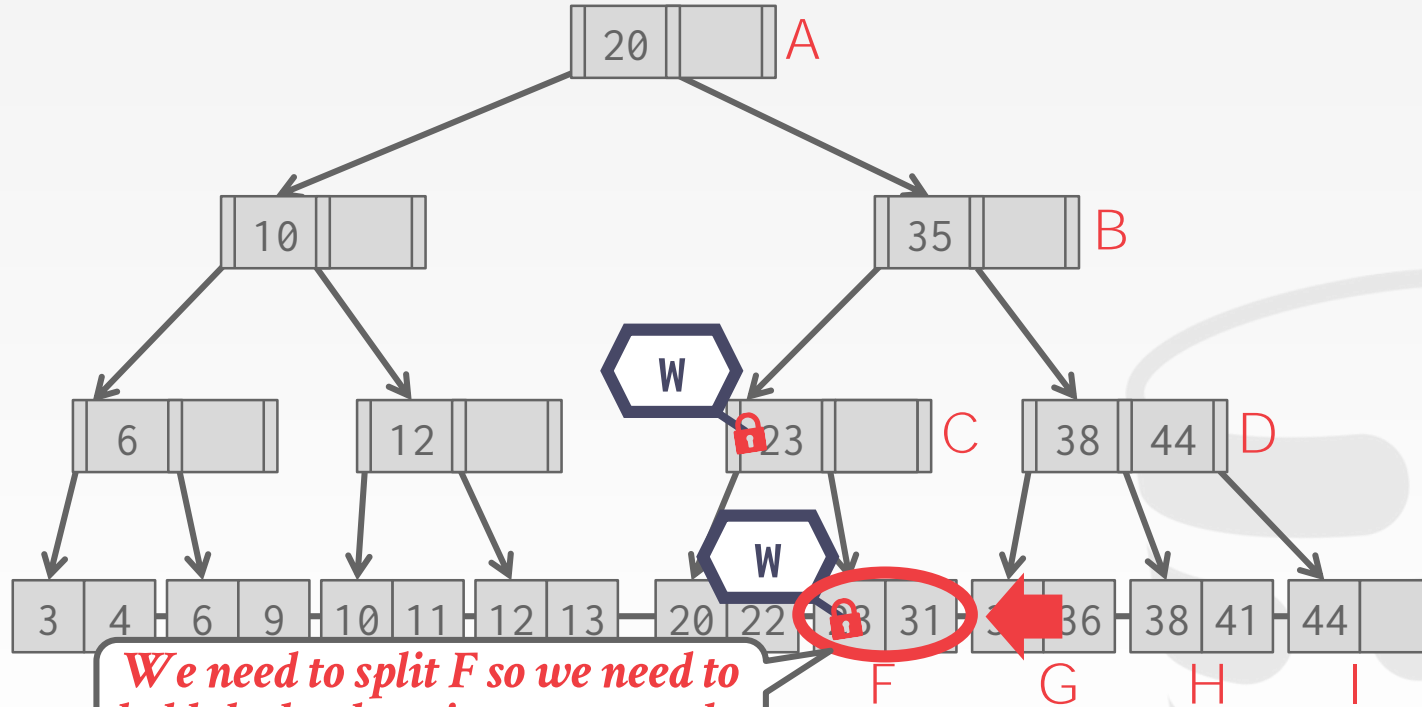

# EXAMPLE #4 – INSERT 25

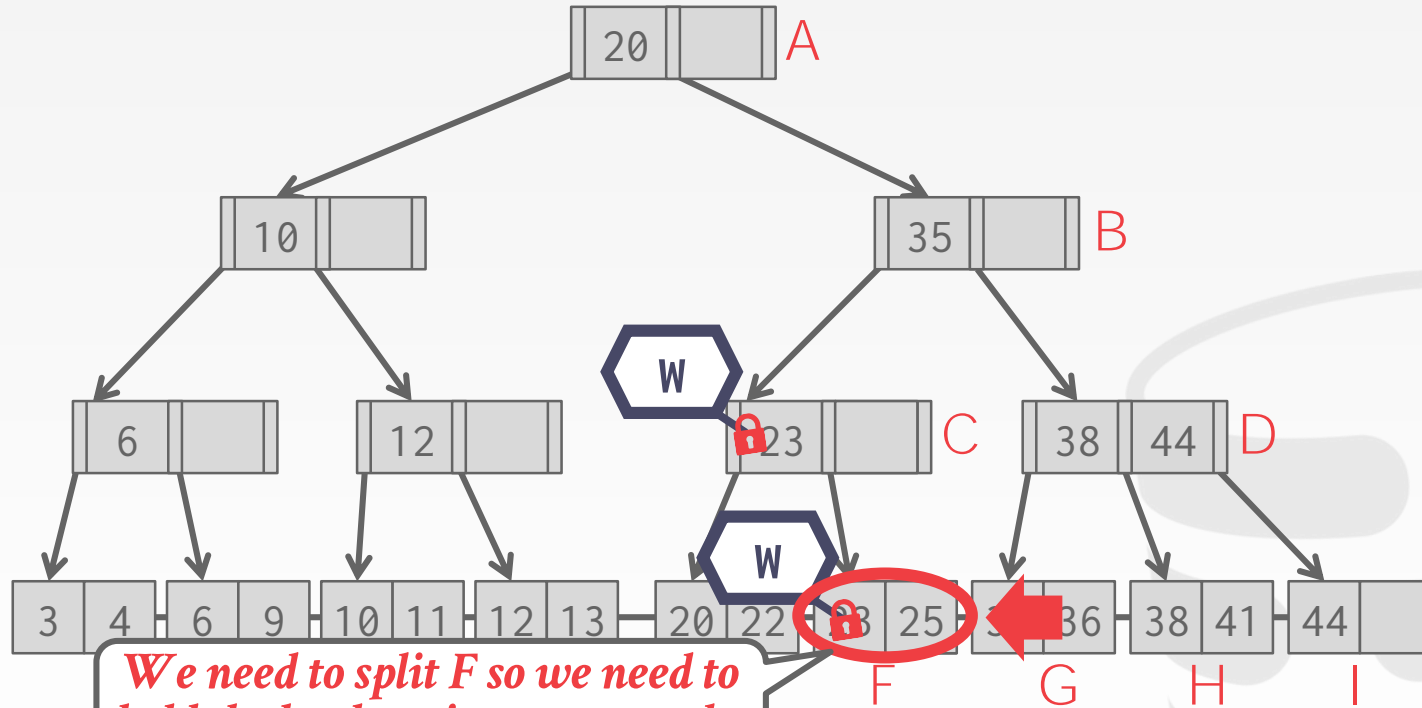



# EXAMPLE #4 – INSERT 25

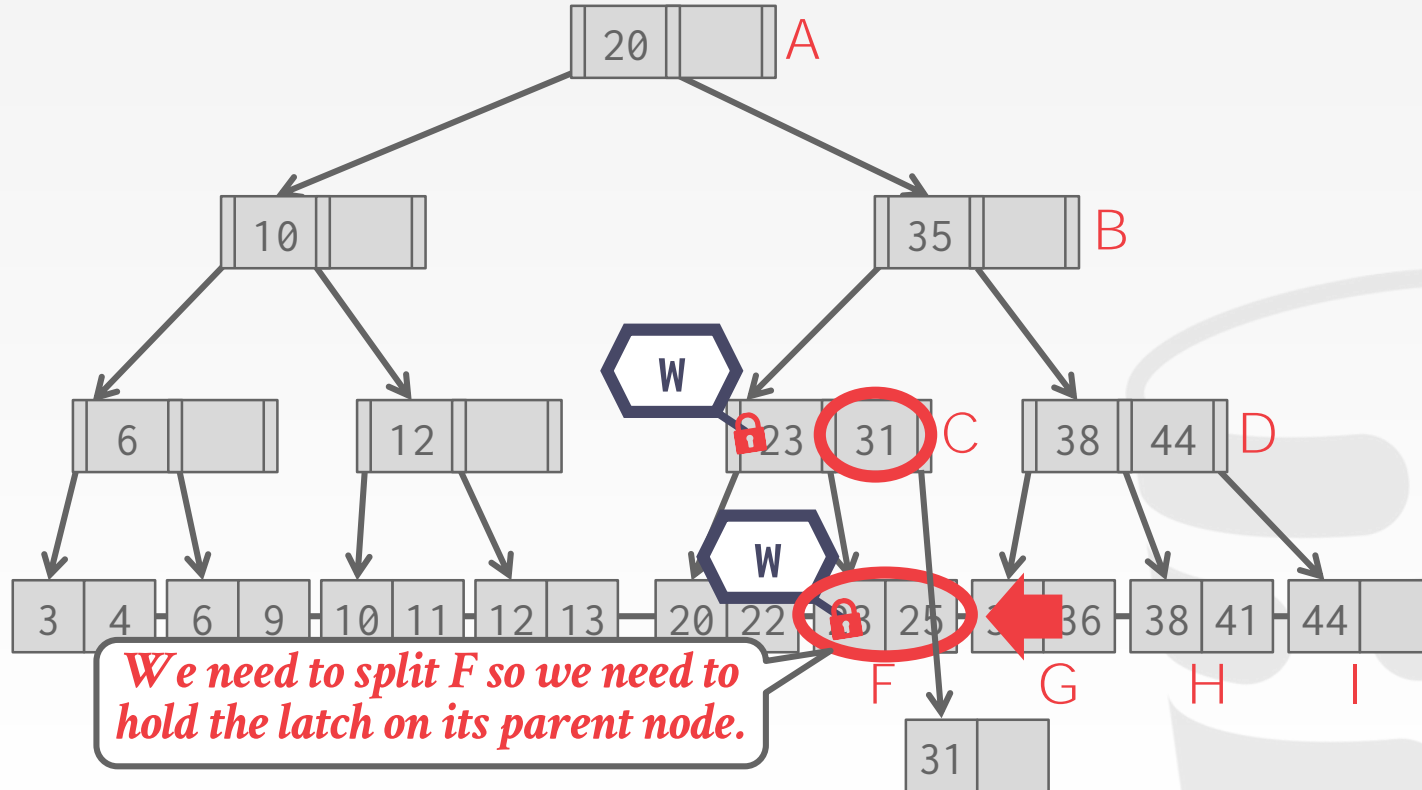

# OBSERVATION

What was the first step that all the update examples did on the B+Tree?

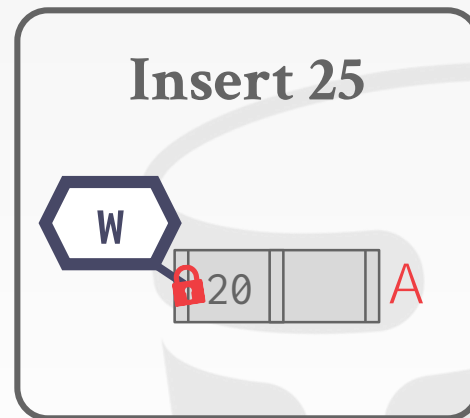
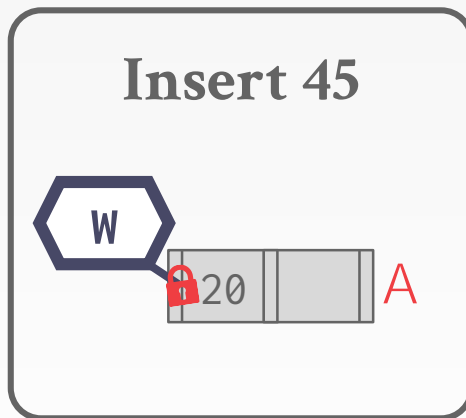
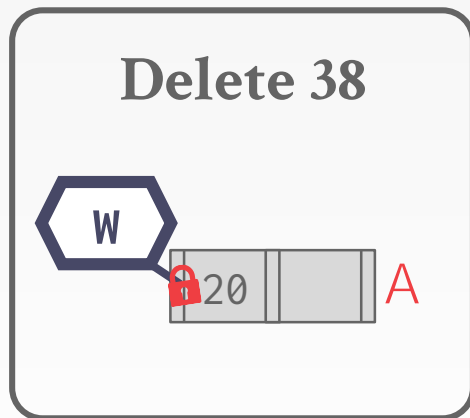

# OBSERVATION

---

What was the first step that all the update examples did on the B+Tree?

Taking a write latch on the root every time becomes a bottleneck with higher concurrency.

Can we do better?

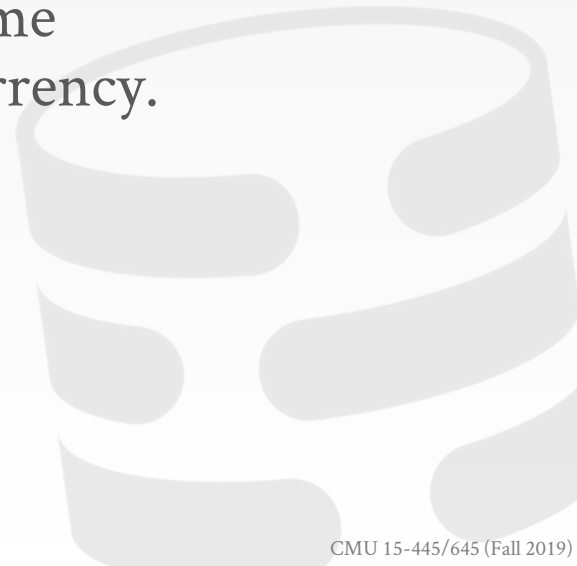

# BETTER LATCHING ALGORITHM

Assume that the leaf node is safe.

Use read latches and crabbing to reach it, and then verify that it is safe.

If leaf is not safe, then do previous algorithm using write latches.

Acta Informatica 9, 1–21 (1977)



## Concurrency of Operations on B-Trees

R. Bayer\* and M. Schkolnick  
IBM Research Laboratory, San José, CA 95193, USA

**Summary.** Concurrent operations on B-trees pose the problem of insuring that each operation can be carried out without interfering with other operations being performed simultaneously by other users. This problem can become critical if these structures are being used to support access paths, like indexes, to data base systems. In this case, serializing access to one of these indexes can create an unacceptable bottleneck for the entire system. Thus, there is a need for locking protocols that can assure integrity for each access while at the same time providing a maximum possible degree of concurrency. Another feature required from these protocols is that they be deadlock free, since the cost to resolve a deadlock may be high.

Recently, there has been some questioning on whether B-tree structures can support concurrent operations. In this paper, we examine the problem of concurrent access to B-trees. We present a deadlock free solution which can be tuned to specific requirements. An analysis is presented which allows the selection of parameters so as to satisfy these requirements.

The solution presented here uses simple locking protocols. Thus, we conclude that B-trees can be used advantageously in a multi-user environment.

### 1. Introduction

In this paper, we examine the problem of concurrent access to indexes which are maintained as B-trees. This type of organization was introduced by Bayer and McCreight [2] and some variants of it appear in Knuth [10] and Wedekind [13]. Performance studies of it were restricted to the single user environment. Recently, these structures have been examined for possible use in a multi-user (concurrent) environment. Some initial studies have been made about the feasibility of their use in this type of situation [1, 6], and [11].

An accessing schema which achieves a high degree of concurrency in using the index will be presented. The schema allows dynamic tuning to adapt its performance to the profile of the current set of users. Another property of the

\* Permanent address: Institut für Informatik der Technischen Universität München, Arcisstr. 21, D-8000 München 2, Germany (Fed. Rep.)

# EXAMPLE #2 – DELETE 38

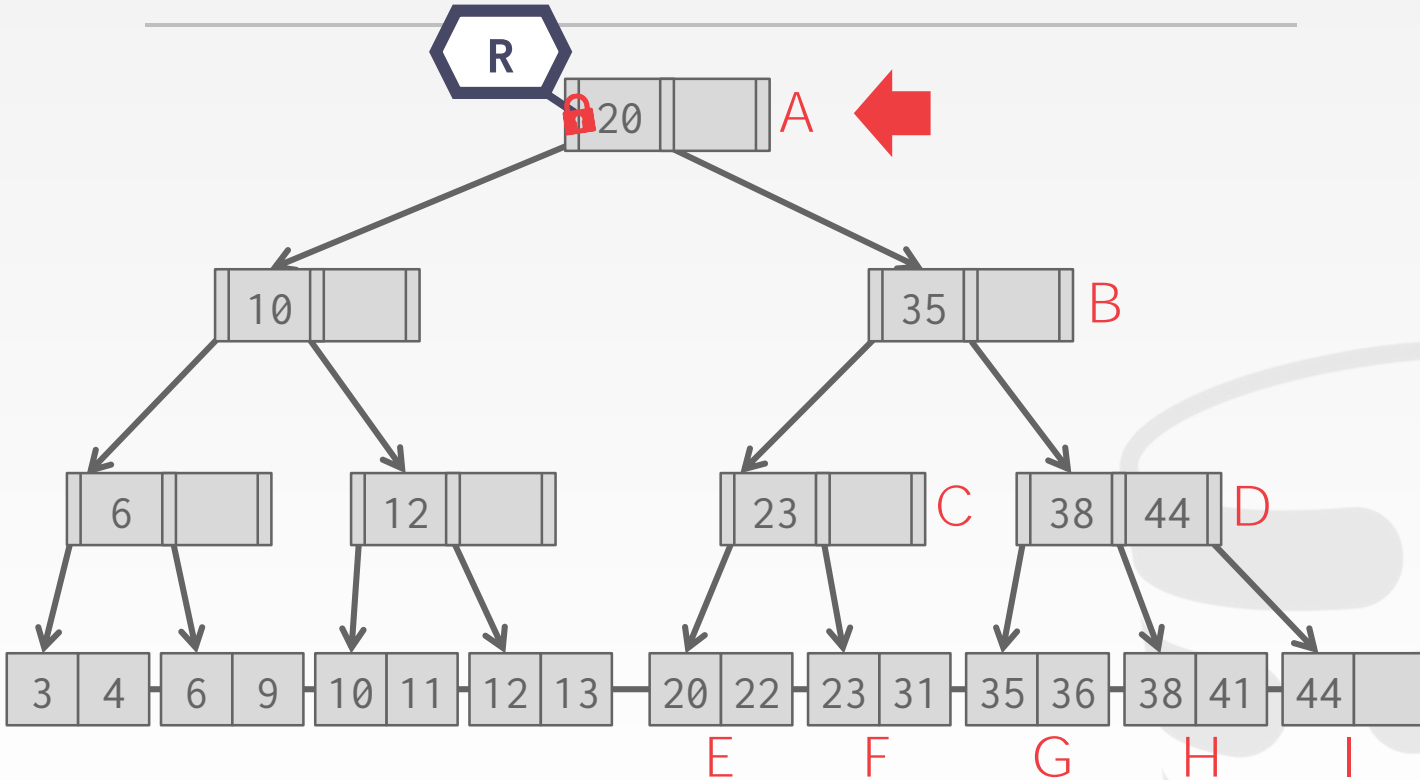

# EXAMPLE #2 – DELETE 38

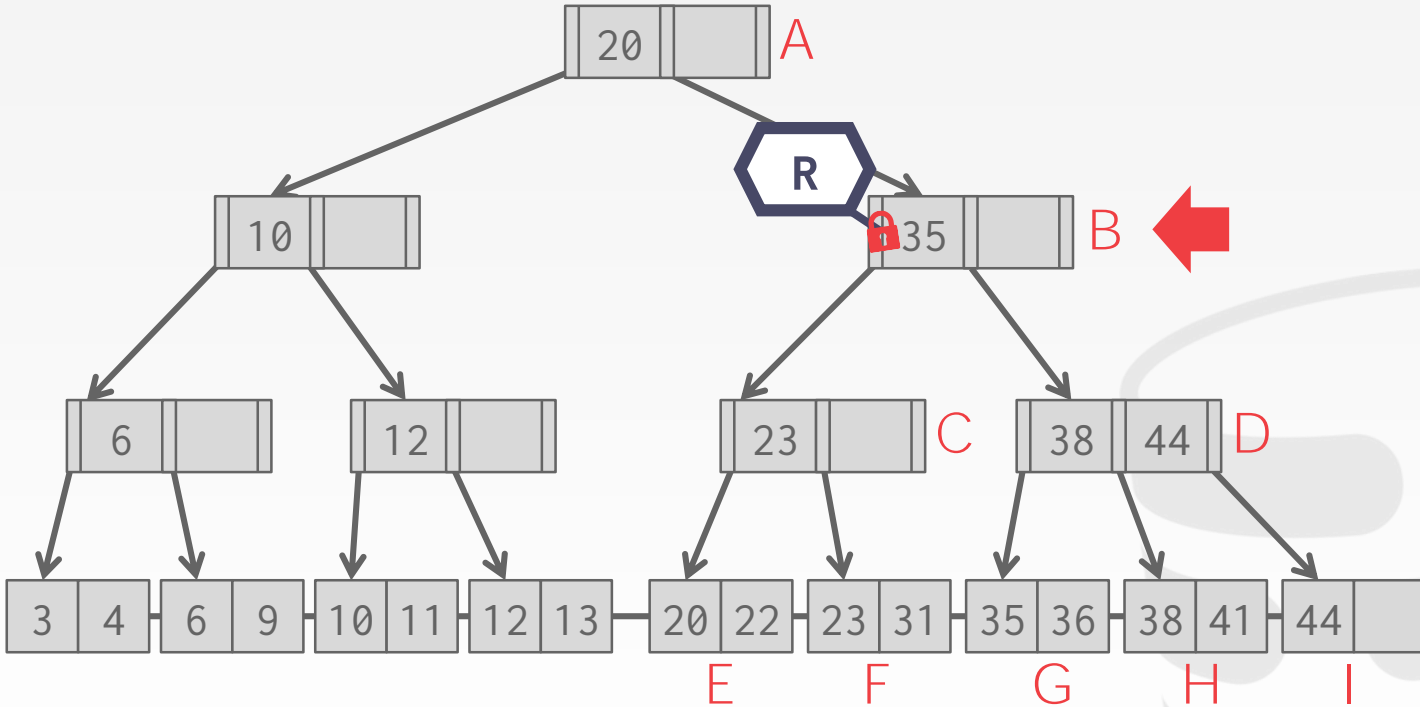

# EXAMPLE #2 – DELETE 38

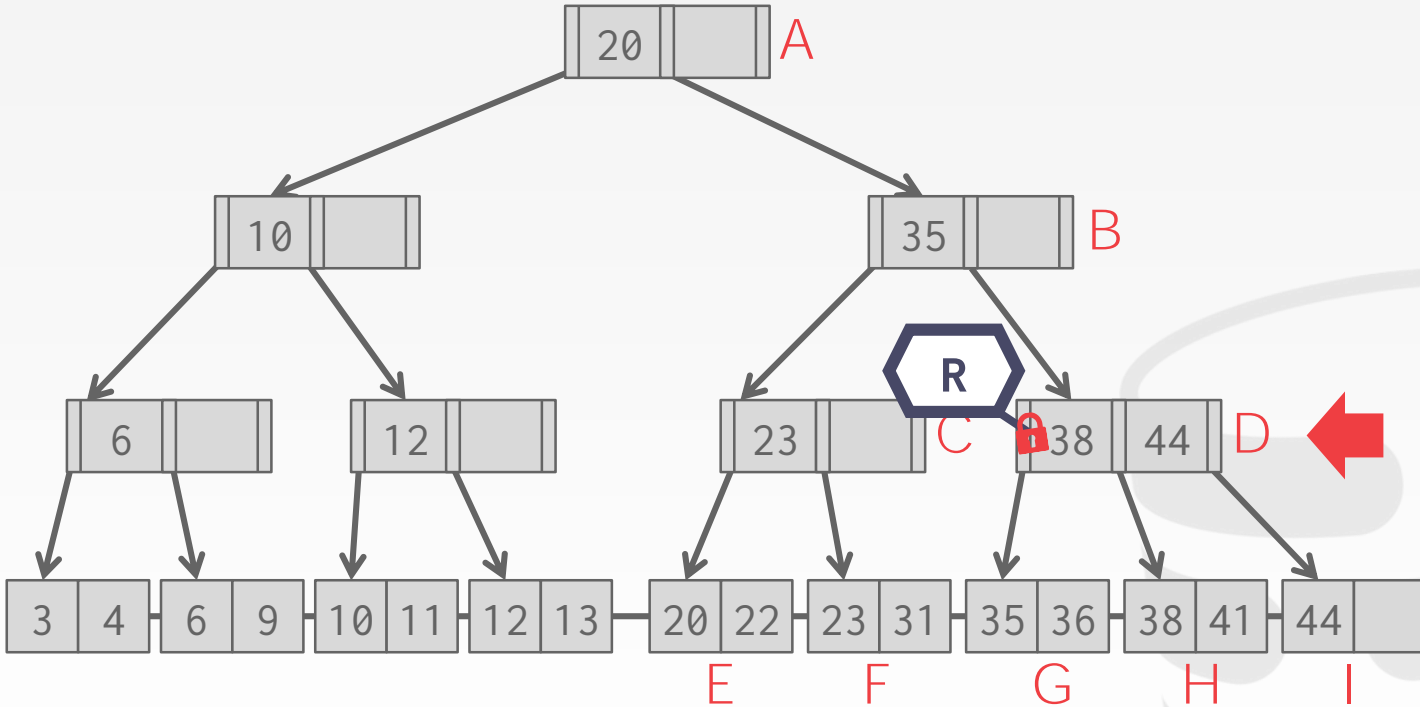

# EXAMPLE #2 – DELETE 38

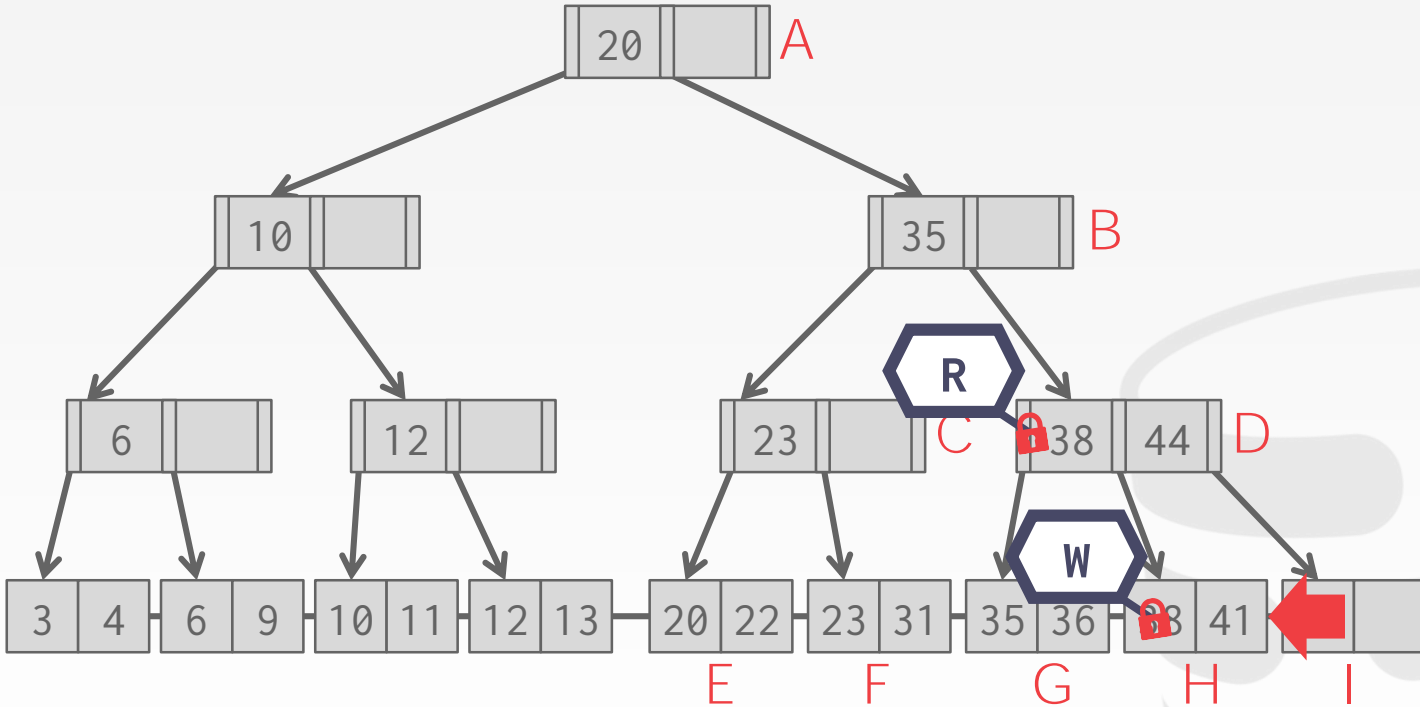



## EXAMPLE #2 – DELETE 38

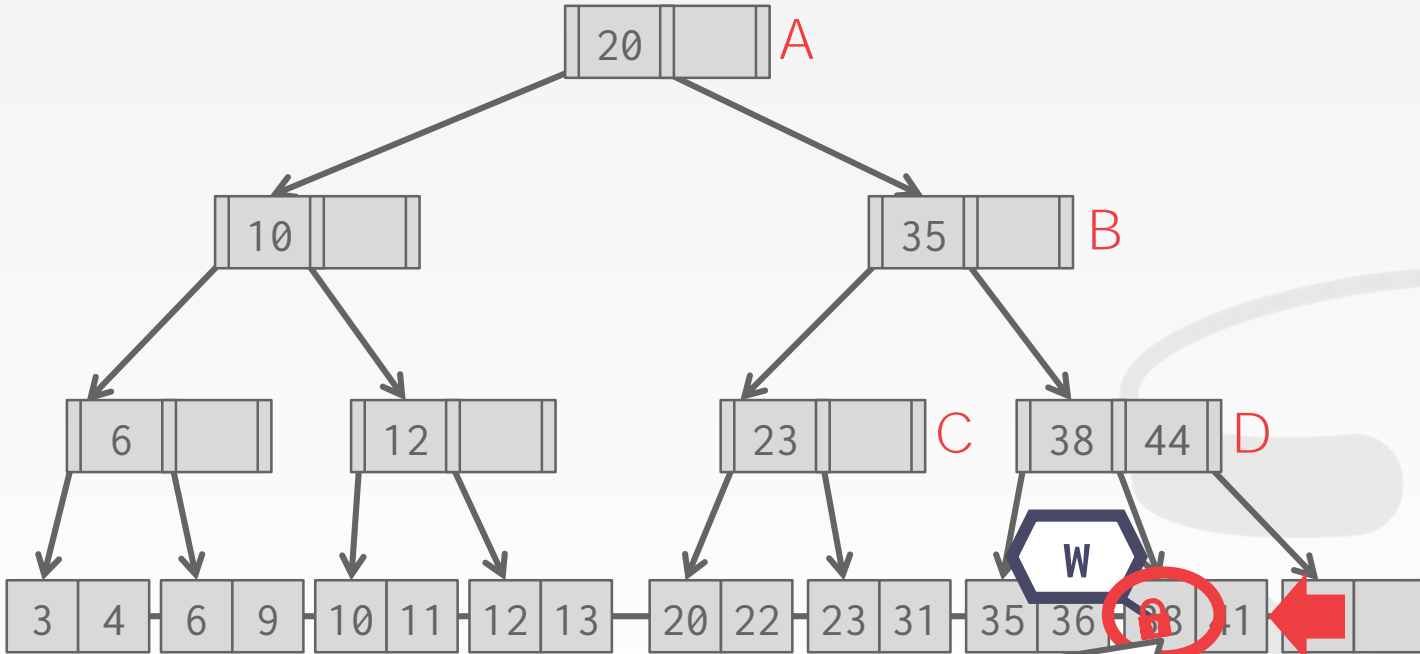

*H will not need to coalesce, so we're safe!*

# EXAMPLE #2 – DELETE 38

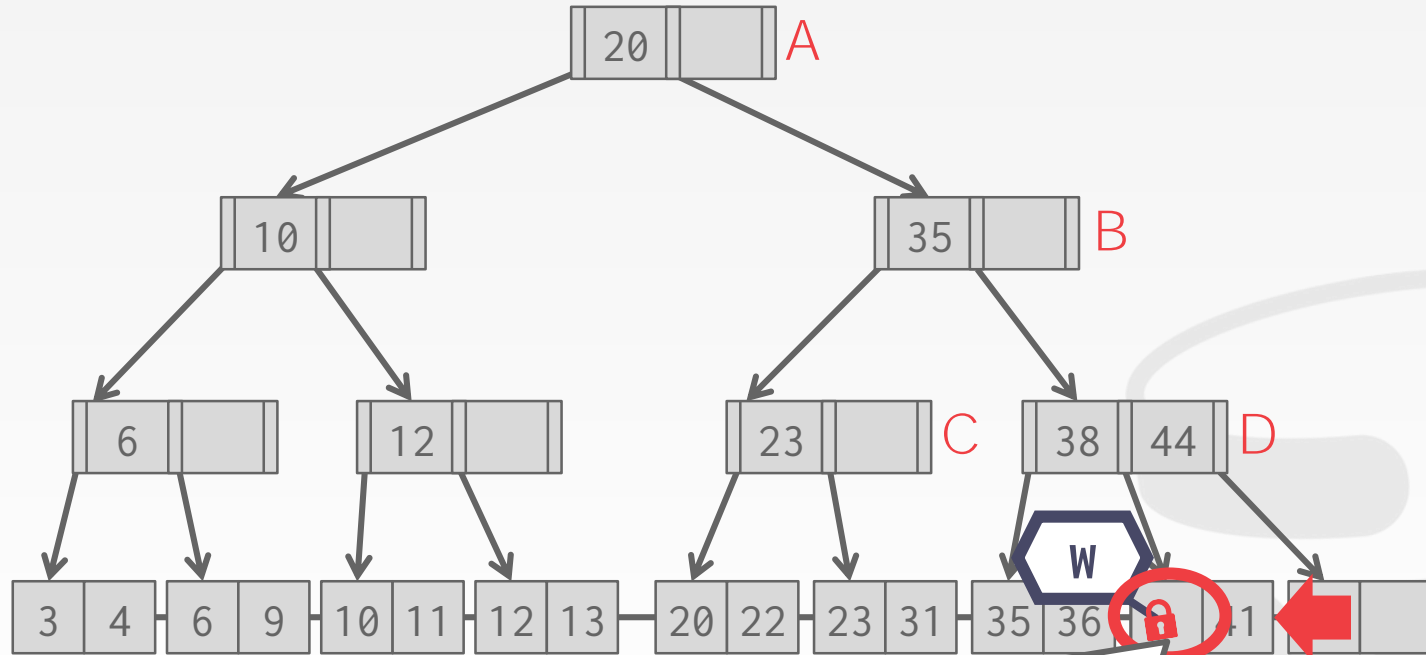

*H will not need to coalesce, so we're safe!*

# EXAMPLE #4 – INSERT 25

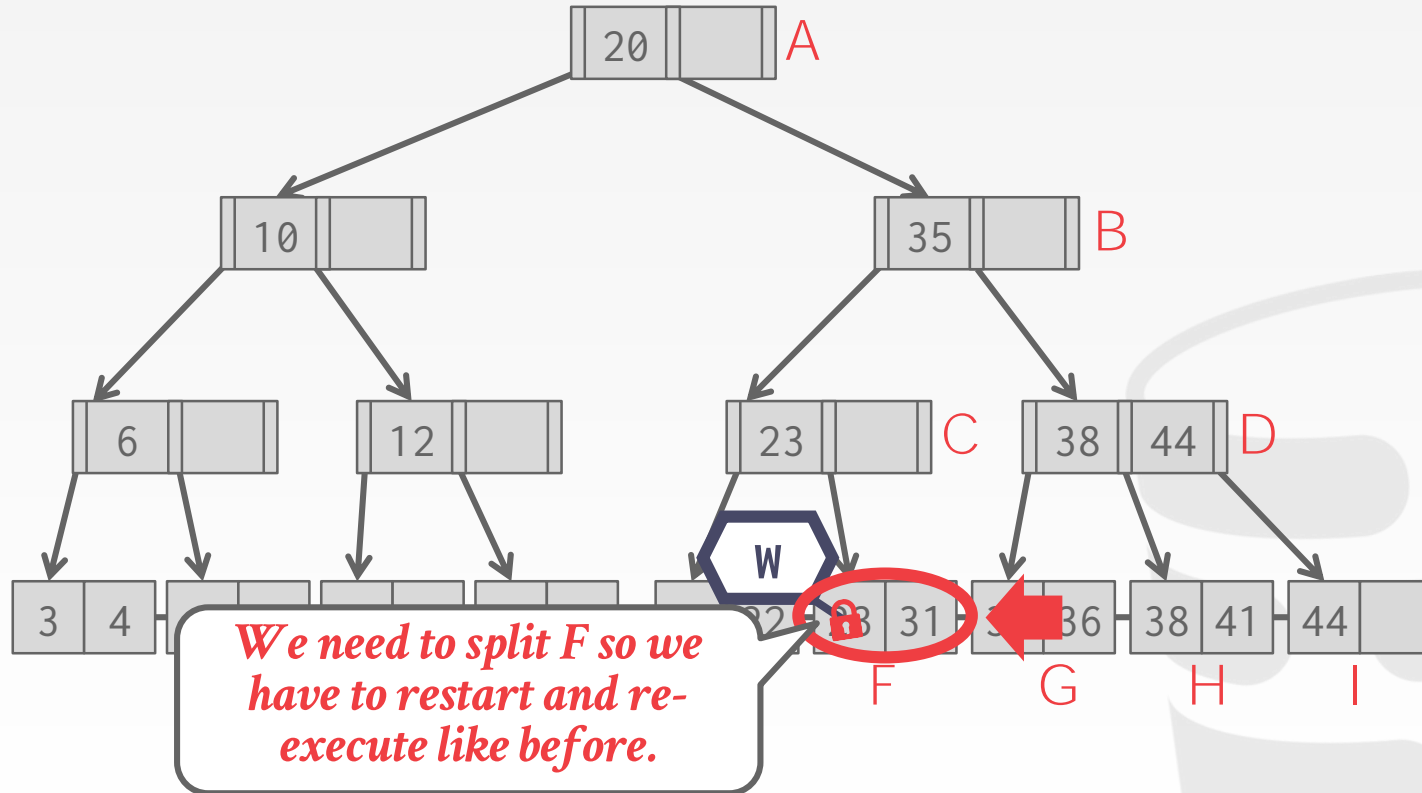

# BETTER LATCHING ALGORITHM

---

**Search:** Same as before.

**Insert/Delete:**

- Set latches as if for search, get to leaf, and set **W** latch on leaf.
- If leaf is not safe, release all latches, and restart thread using previous insert/delete protocol with write latches.

This approach optimistically assumes that only leaf node will be modified; if not, **R** latches set on the first pass to leaf are wasteful.

# OBSERVATION

---

The threads in all the examples so far have acquired latches in a "top-down" manner.

- A thread can only acquire a latch from a node that is below its current node.
- If the desired latch is unavailable, the thread must wait until it becomes available.

But what if we want to move from one leaf node to another leaf node?

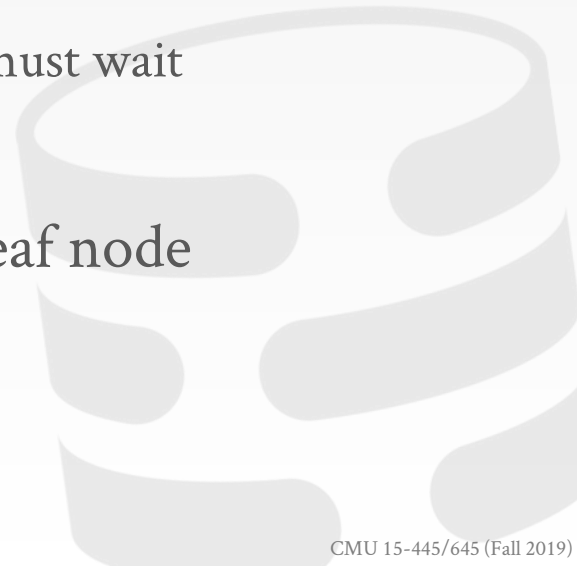

# LEAF NODE SCAN EXAMPLE #1

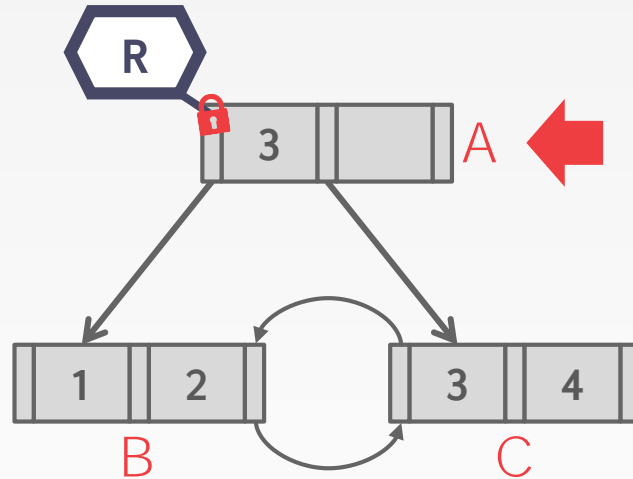

$T_1$ : Find Keys < 4

# LEAF NODE SCAN EXAMPLE #1

$T_1$ : Find Keys < 4

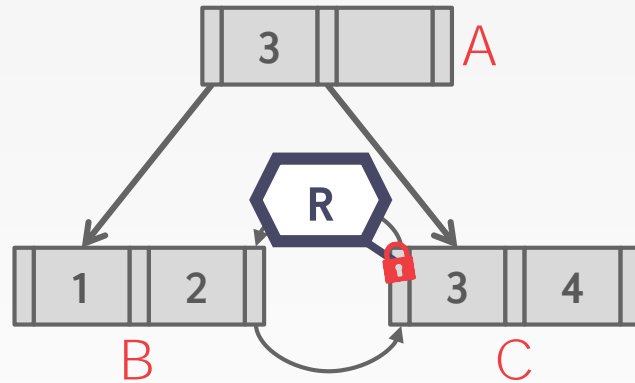

# LEAF NODE SCAN EXAMPLE #1

$T_1$ : Find Keys < 4

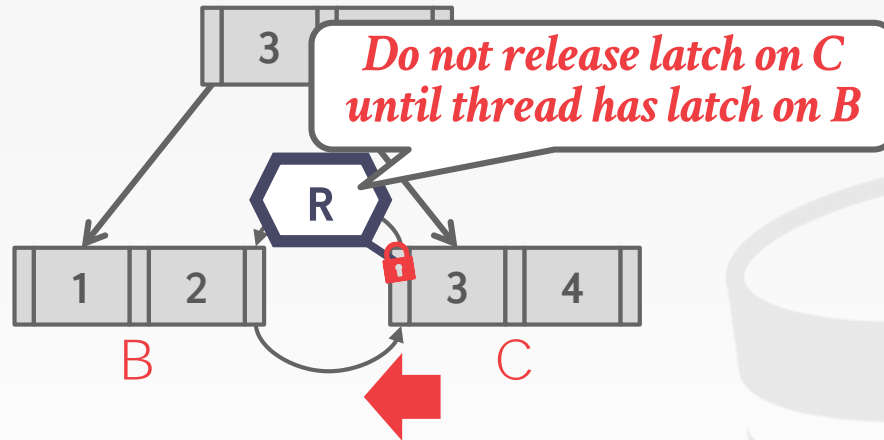



# LEAF NODE SCAN EXAMPLE #1

$T_1$ : Find Keys < 4

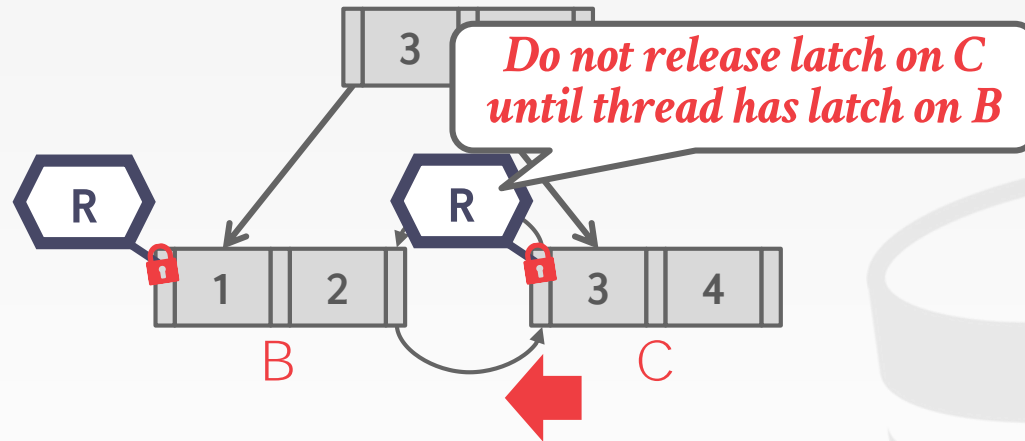

# LEAF NODE SCAN EXAMPLE #1

$T_1$ : Find Keys < 4

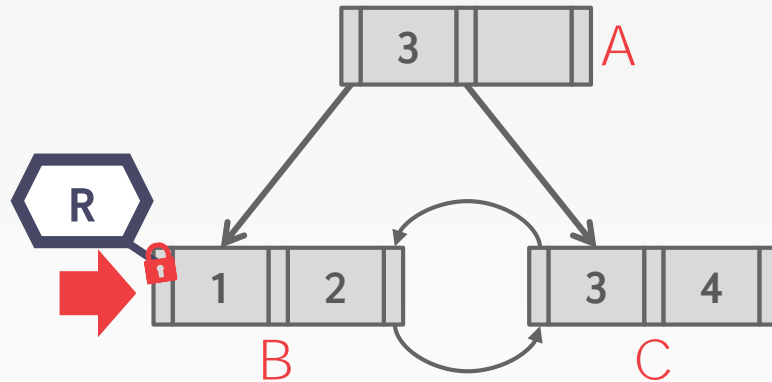

# LEAF NODE SCAN EXAMPLE #2

$T_1$ : Find Keys  $< 4$

$T_2$ : Find Keys  $> 1$

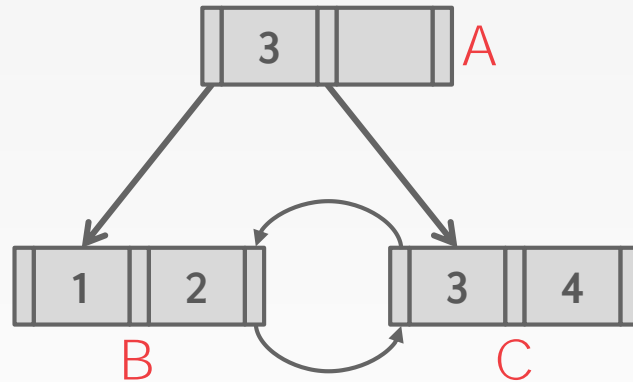

# LEAF NODE SCAN EXAMPLE #2

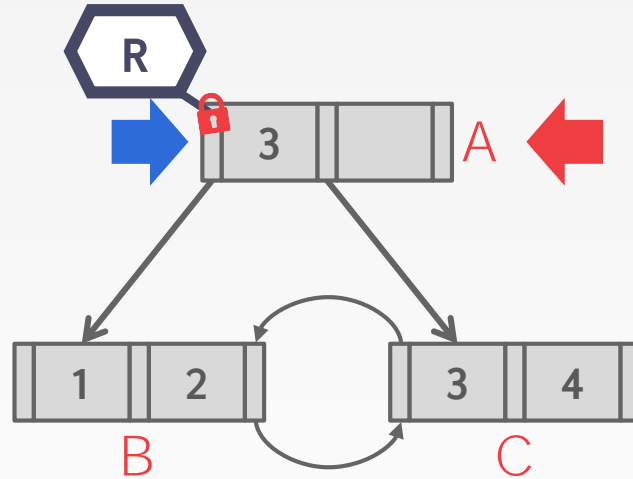

$T_1$ : Find Keys  $< 4$   
 $T_2$ : Find Keys  $> 1$

# LEAF NODE SCAN EXAMPLE #2

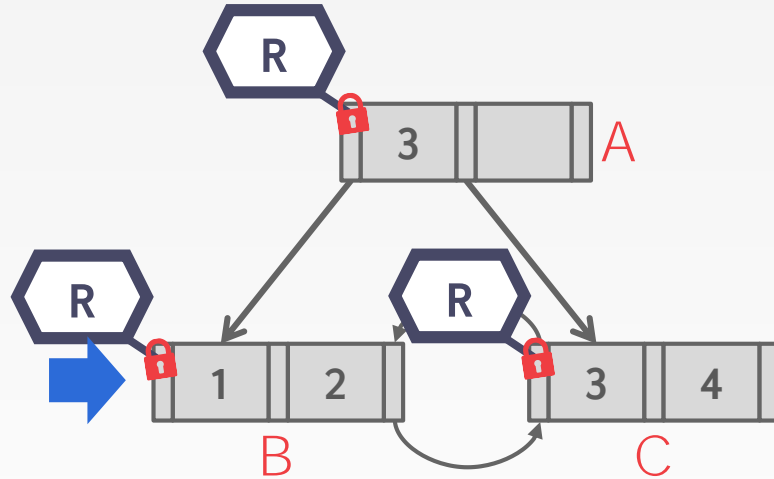

$T_1$ : Find Keys  $< 4$

$T_2$ : Find Keys  $> 1$

# LEAF NODE SCAN EXAMPLE #2

$T_1$ : Find Keys  $< 4$

$T_2$ : Find Keys  $> 1$

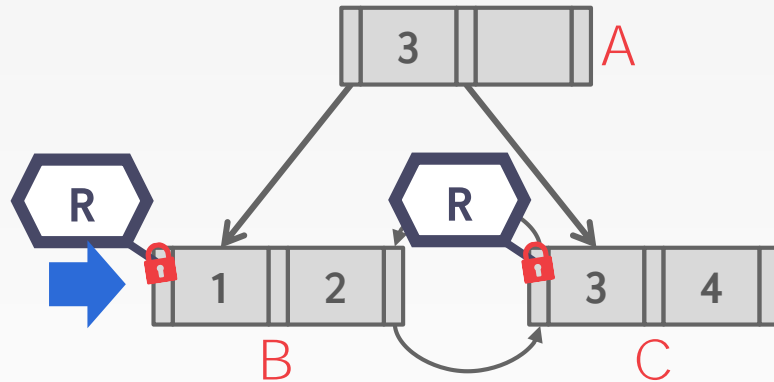

# LEAF NODE SCAN EXAMPLE #2

$T_1$ : Find Keys < 4

$T_2$ : Find Keys > 1

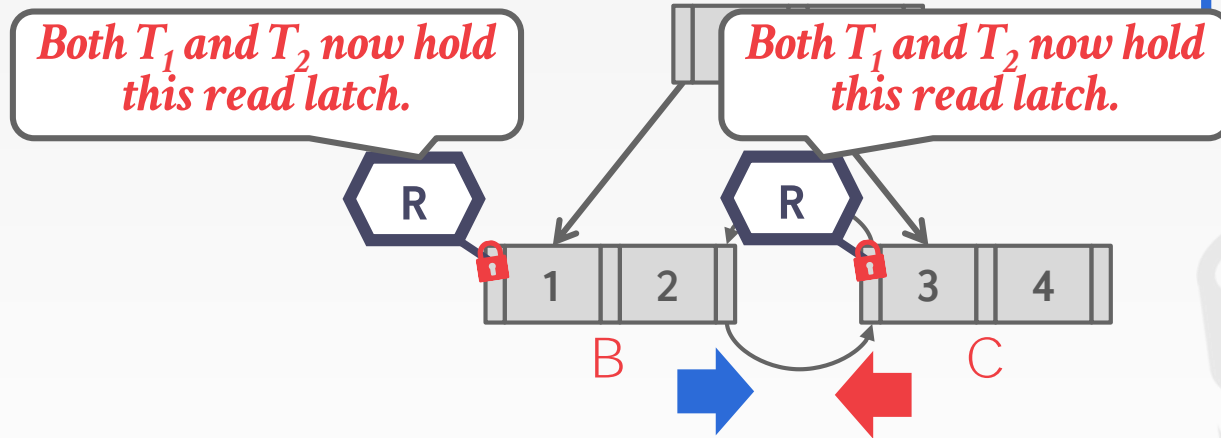

# LEAF NODE SCAN EXAMPLE #2

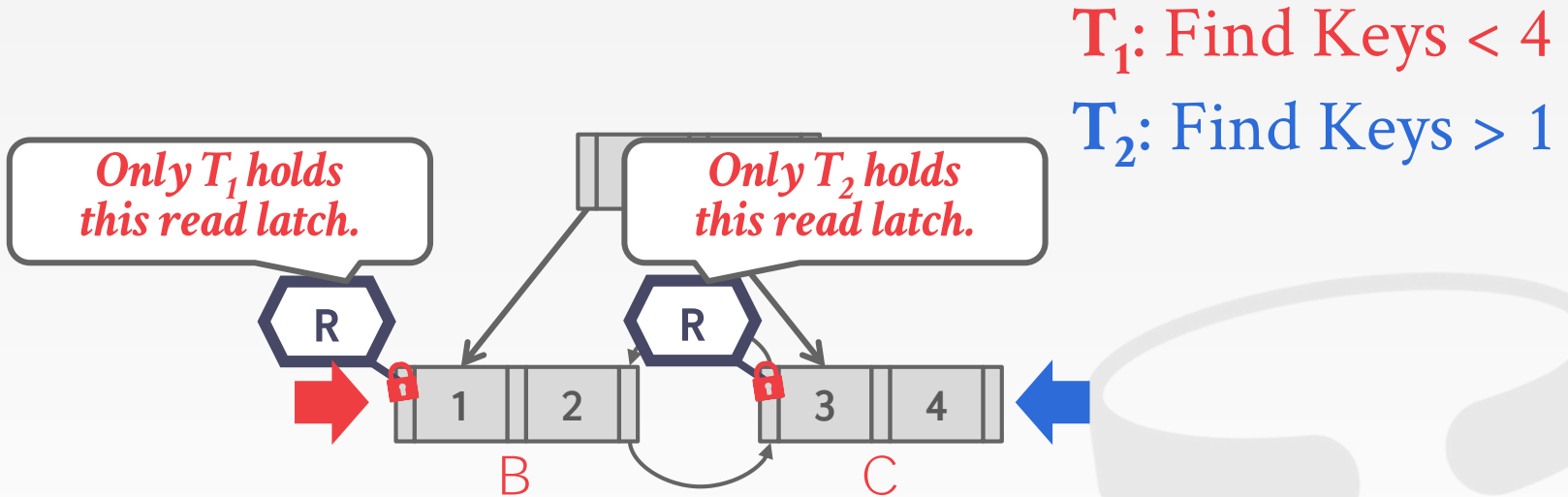



# LEAF NODE SCAN EXAMPLE #3

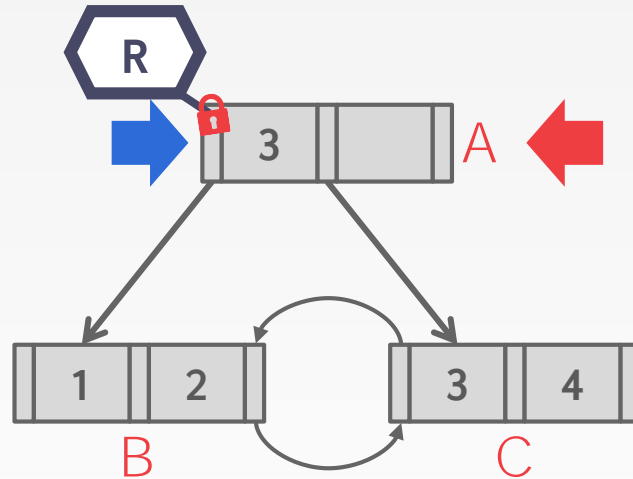

$T_1$ : Delete 4

$T_2$ : Find Keys > 1

# LEAF NODE SCAN EXAMPLE #3

$T_1$ : Delete 4  
 $T_2$ : Find Keys > 1

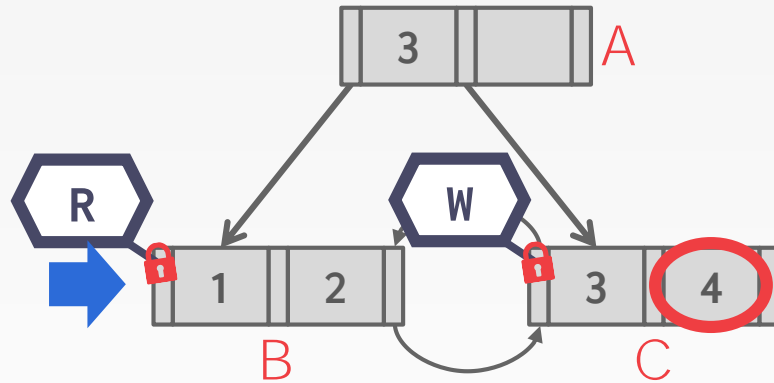

# LEAF NODE SCAN EXAMPLE #3

$T_1$ : Delete 4

$T_2$ : Find Keys > 1

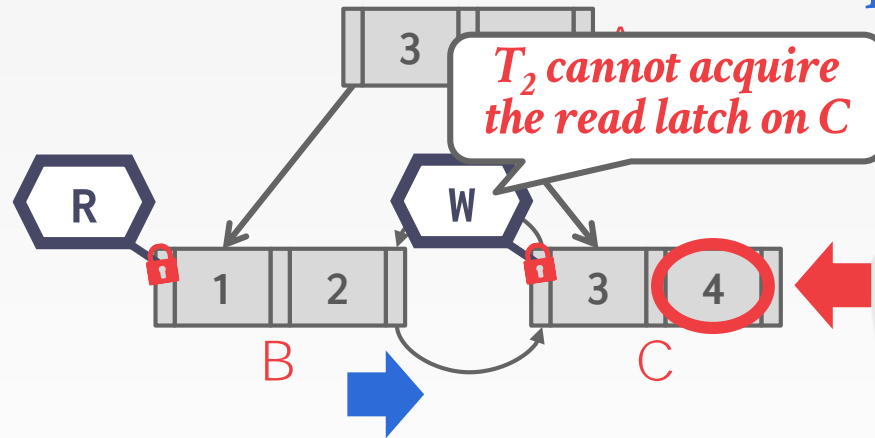

# LEAF NODE SCAN EXAMPLE #3

$T_1$ : Delete 4

$T_2$ : Find Keys > 1

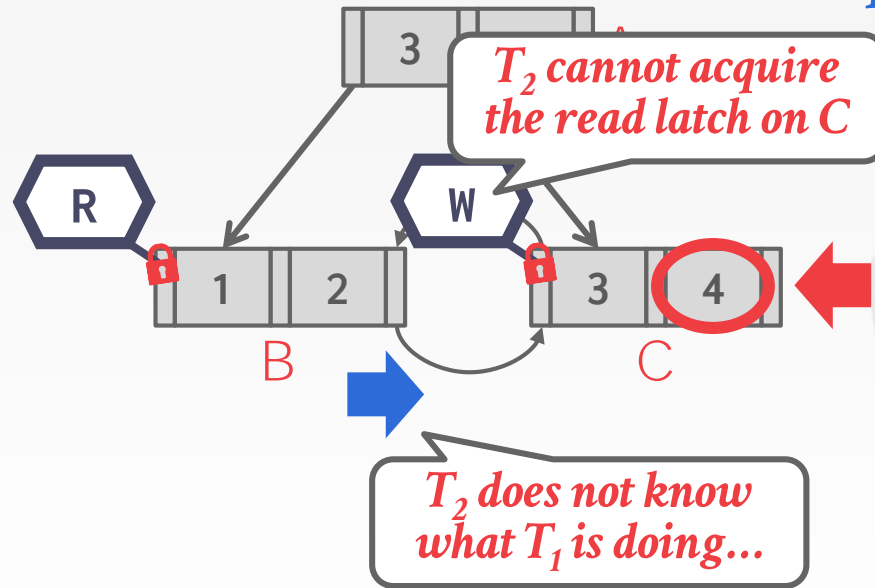

# LEAF NODE SCAN EXAMPLE #3

$T_1$ : Delete 4

$T_2$ : Find Keys > 1

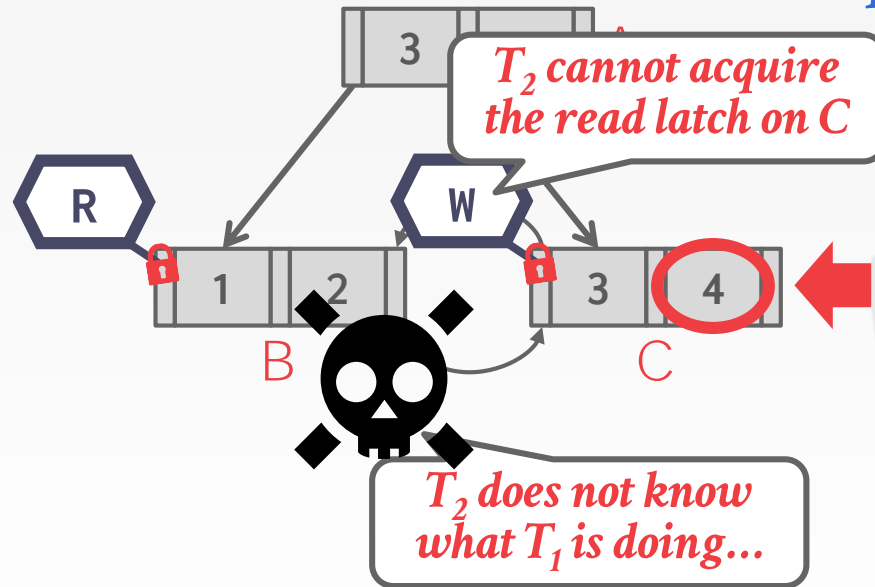

# LEAF NODE SCANS

---

Latches do not support deadlock detection or avoidance. The only way we can deal with this problem is through coding discipline.

The leaf node sibling latch acquisition protocol must support a "no-wait" mode.

The DBMS's data structures must cope with failed latch acquisitions.

# DELAYED PARENT UPDATES

---

Every time a leaf node overflows, we must update at least three nodes.

- The leaf node being split.
- The new leaf node being created.
- The parent node.

**B<sup>link</sup>-Tree Optimization:** When a leaf node overflows, delay updating its parent node.

# EXAMPLE #4 – INSERT 25

$T_1$ : Insert 25

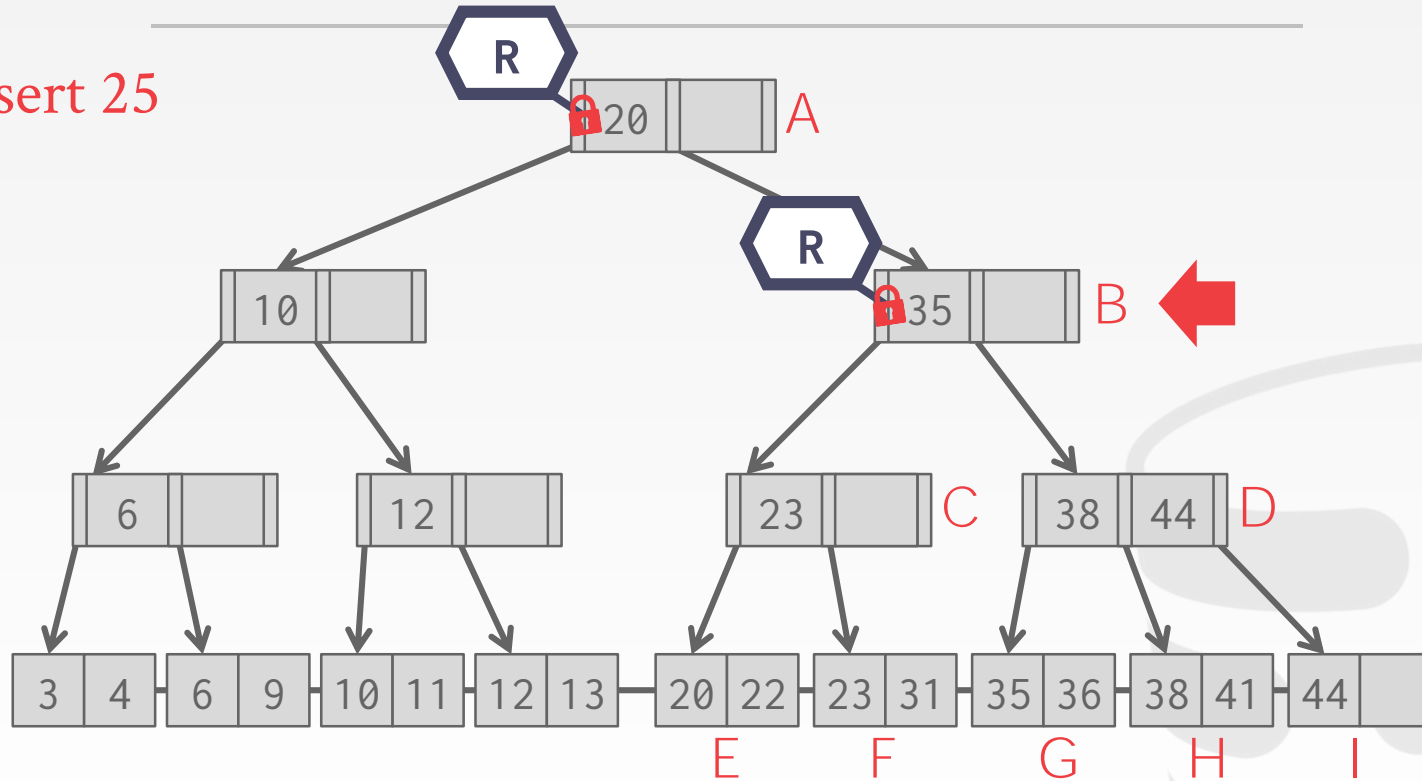



# EXAMPLE #4 – INSERT 25

$T_1$ : Insert 25

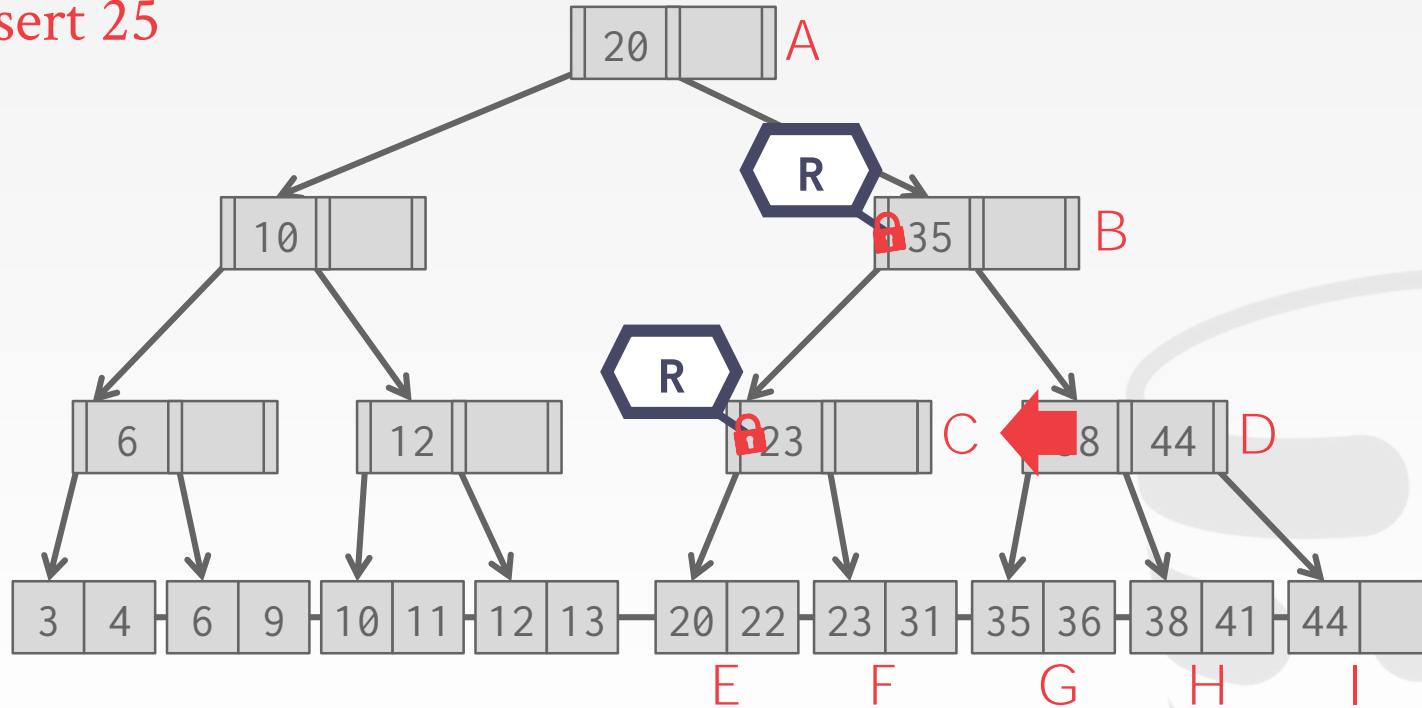

# EXAMPLE #4 – INSERT 25

$T_1$ : Insert 25

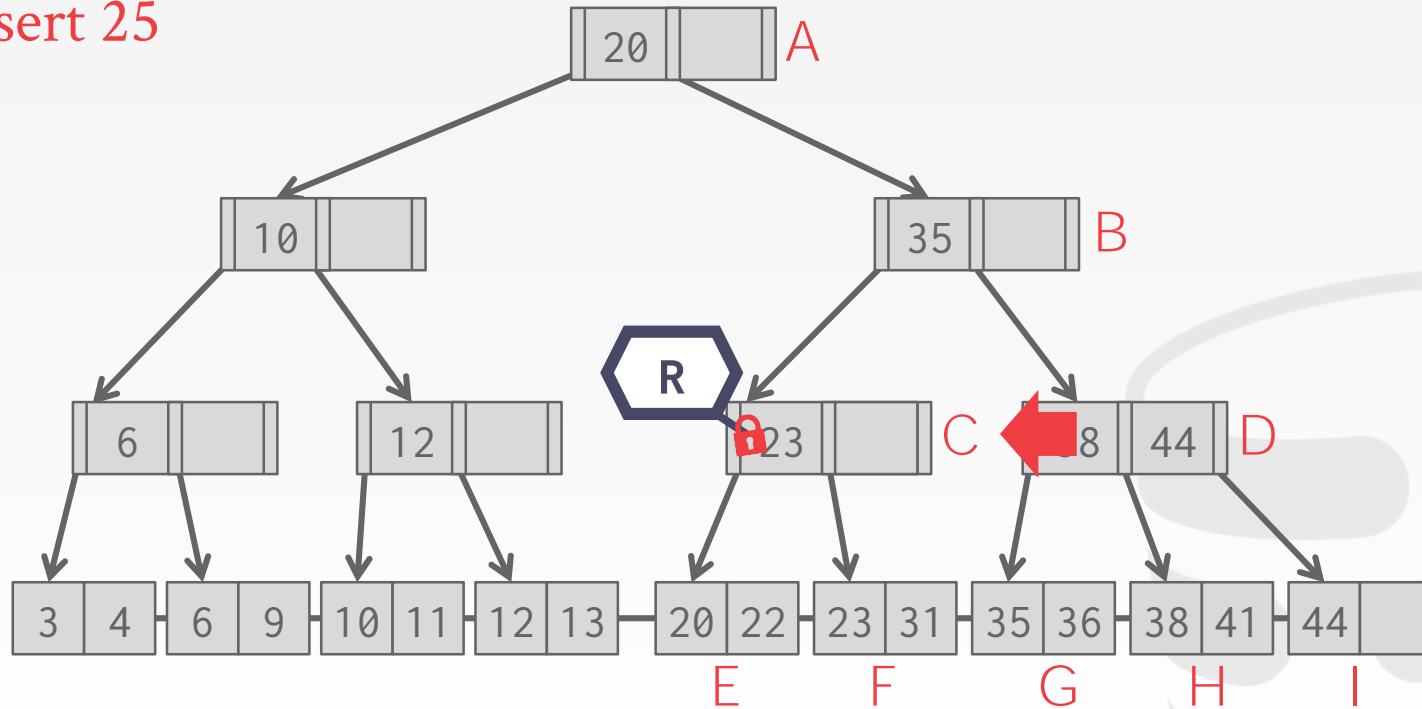

# EXAMPLE #4 – INSERT 25

$T_1$ : Insert 25

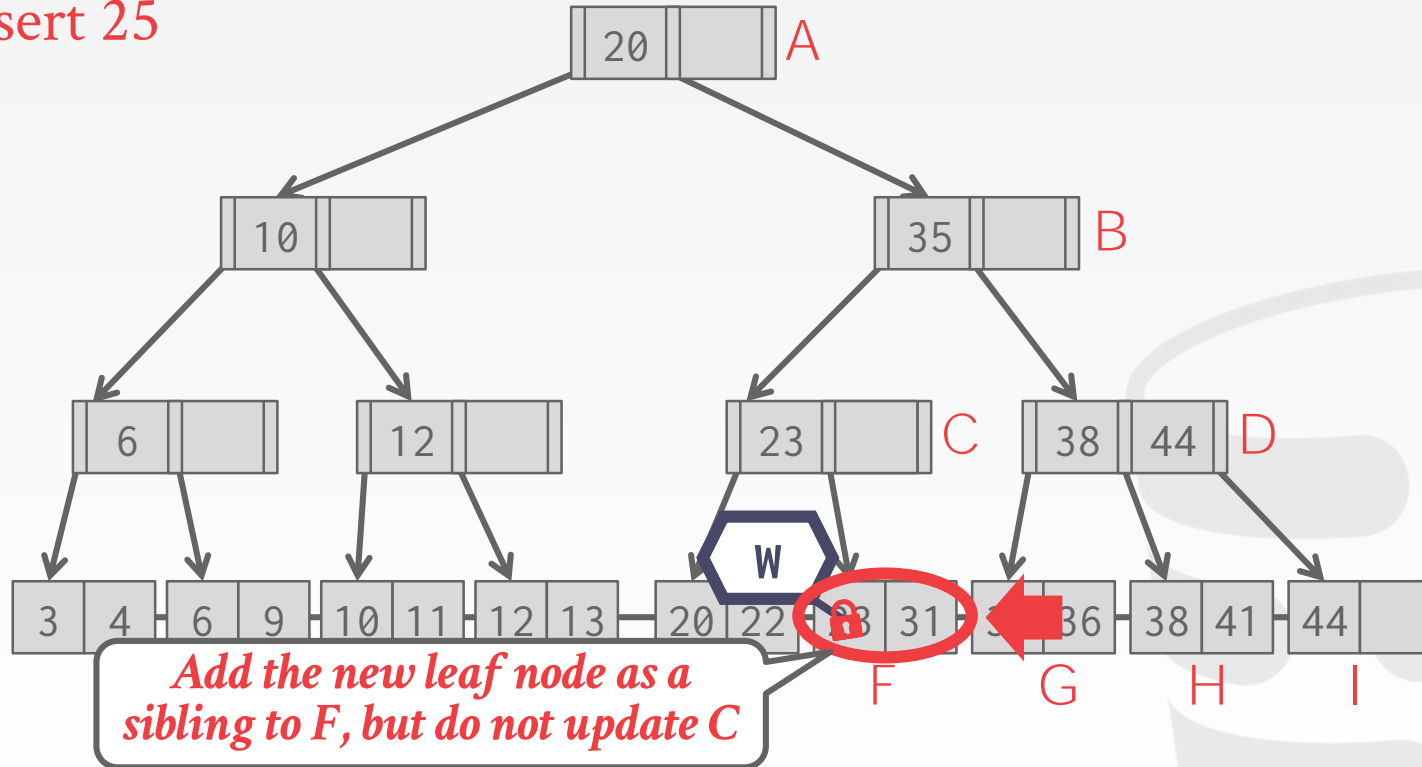

# EXAMPLE #4 – INSERT 25

$T_1$ : Insert 25

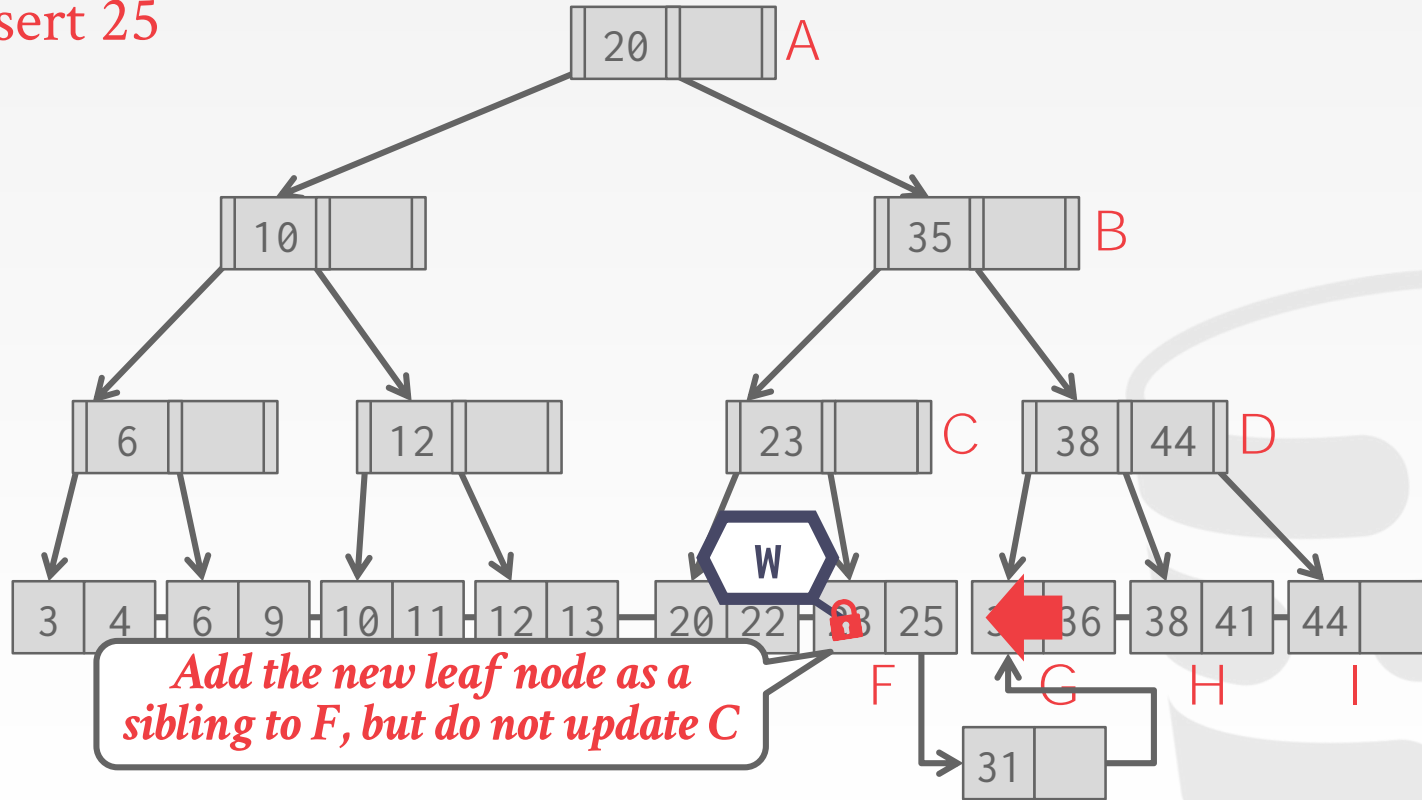

# EXAMPLE #4 – INSERT 25

$T_1$ : Insert 25

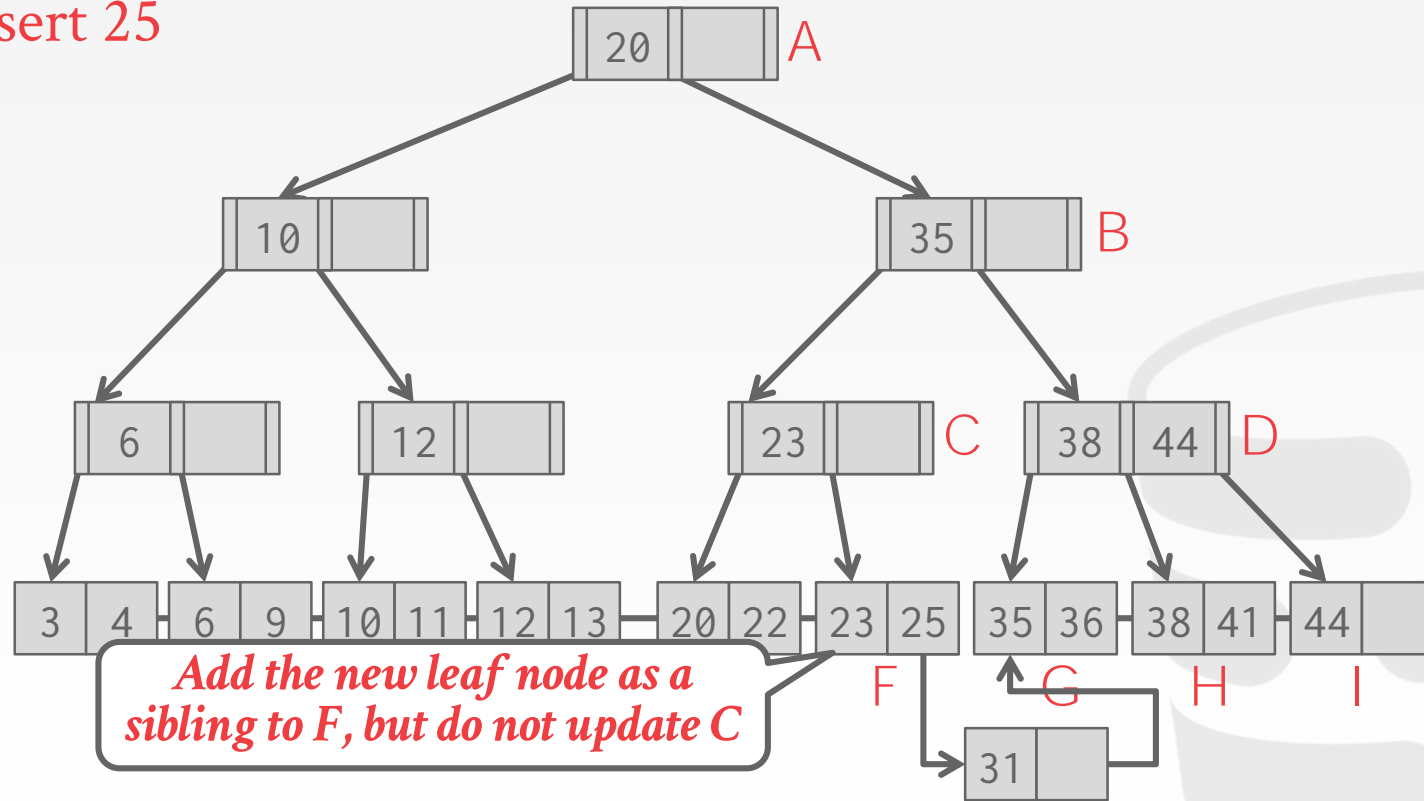

# EXAMPLE #4 – INSERT 25

$T_1$ : Insert 25

★ C: Add 31

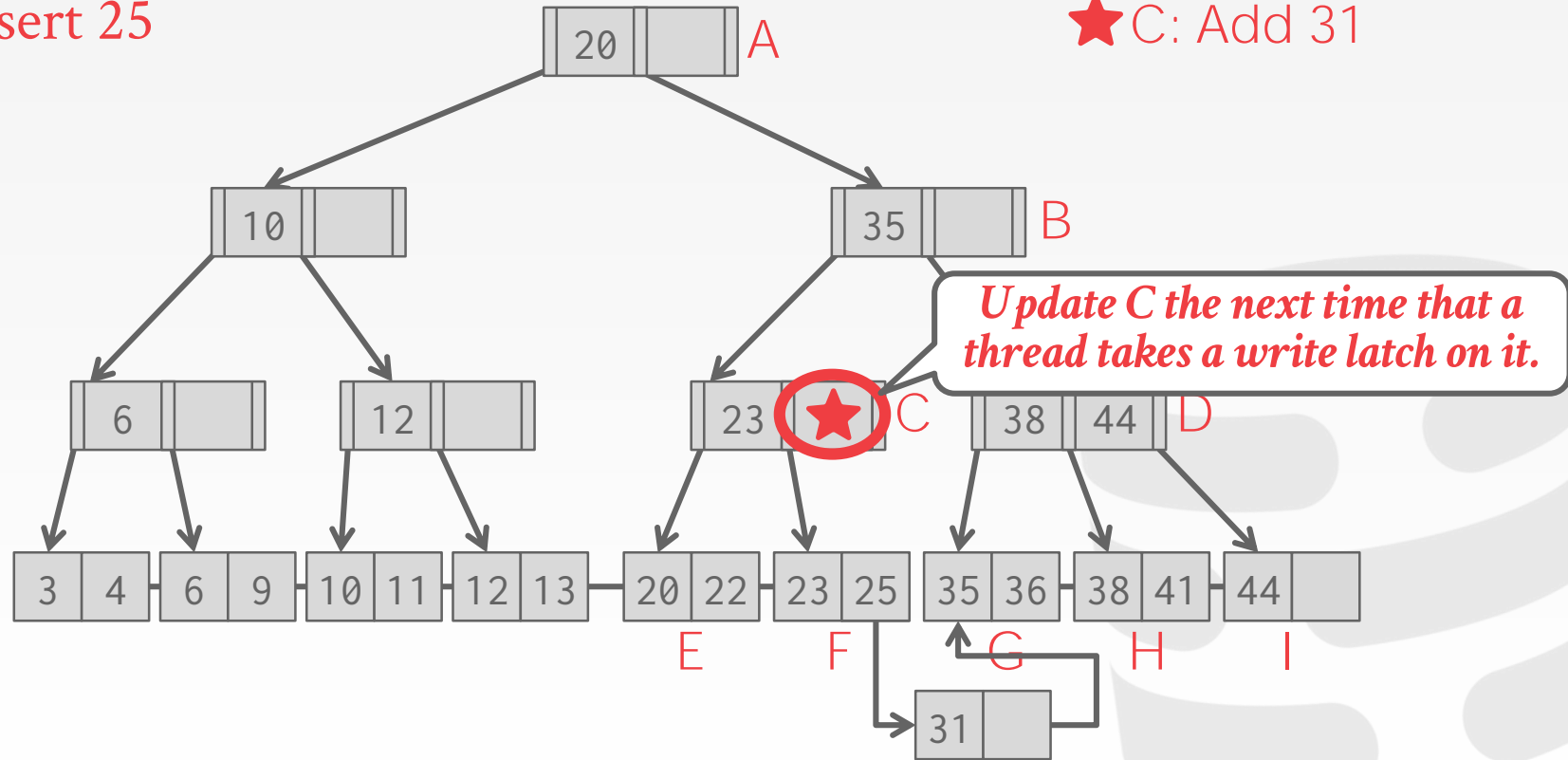

# EXAMPLE #4 – INSERT 25

$T_1$ : Insert 25

$T_2$ : Find 31

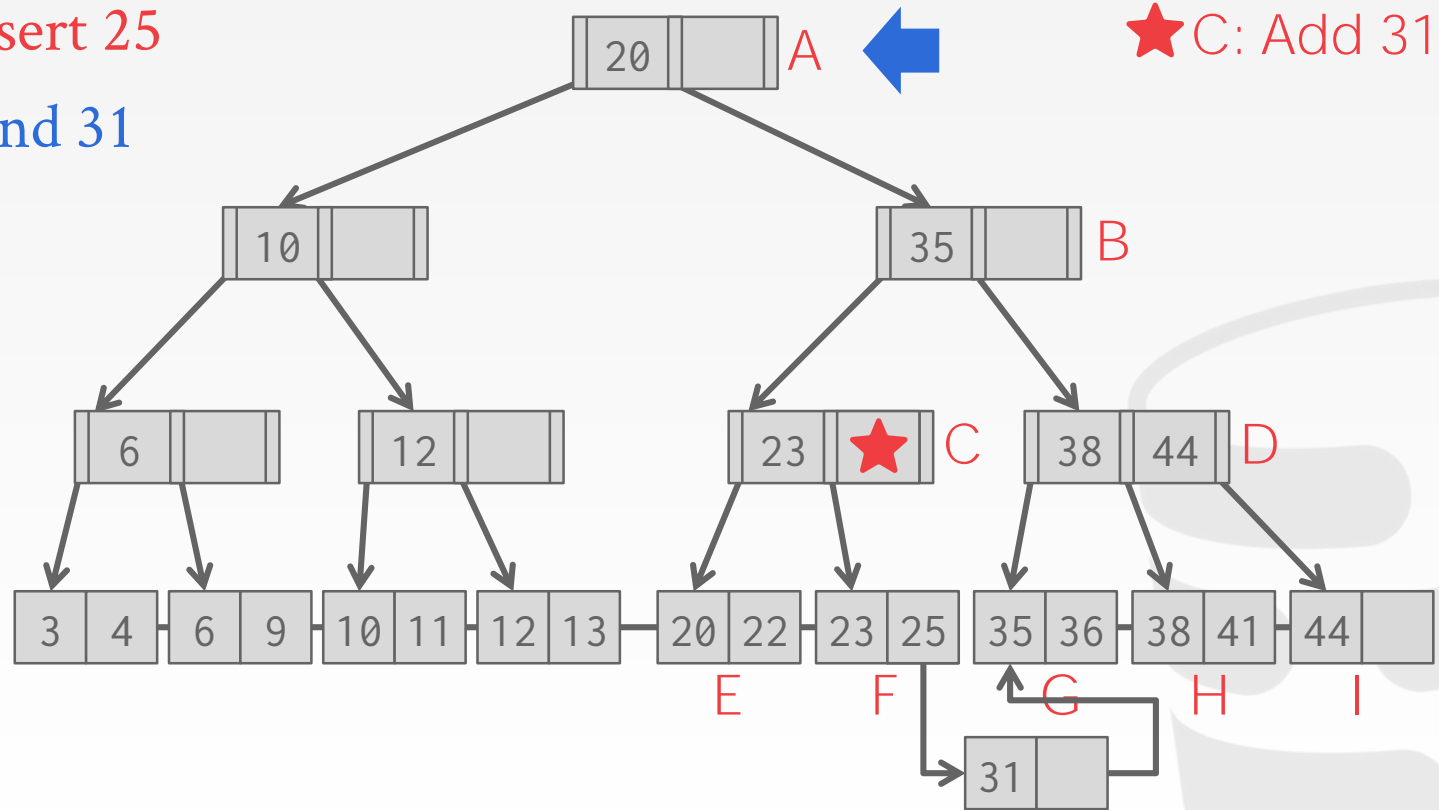

# EXAMPLE #4 – INSERT 25

$T_1$ : Insert 25

$T_2$ : Find 31

★ C: Add 31

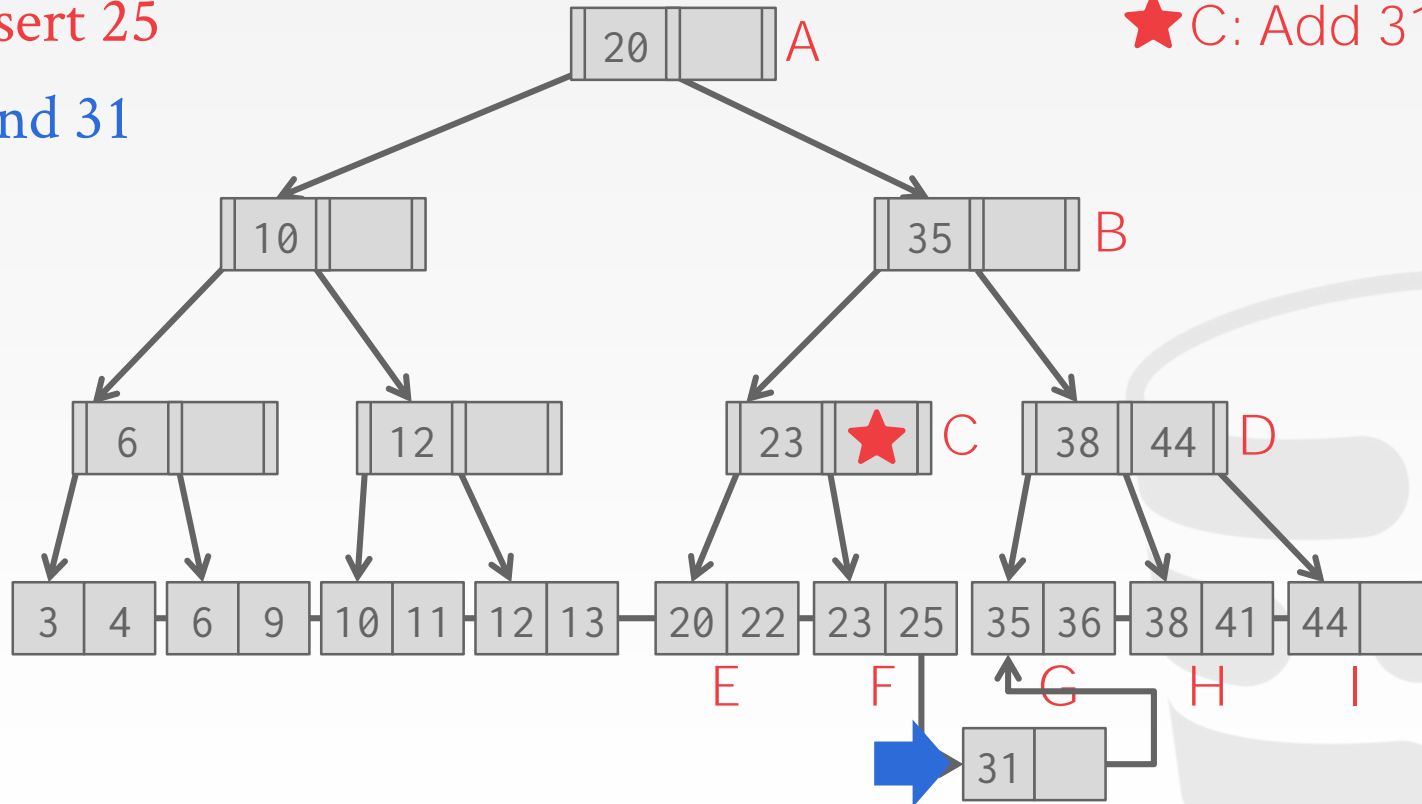



# EXAMPLE #4 – INSERT 25

$T_1$ : Insert 25

$T_2$ : Find 31

$T_3$ : Insert 33

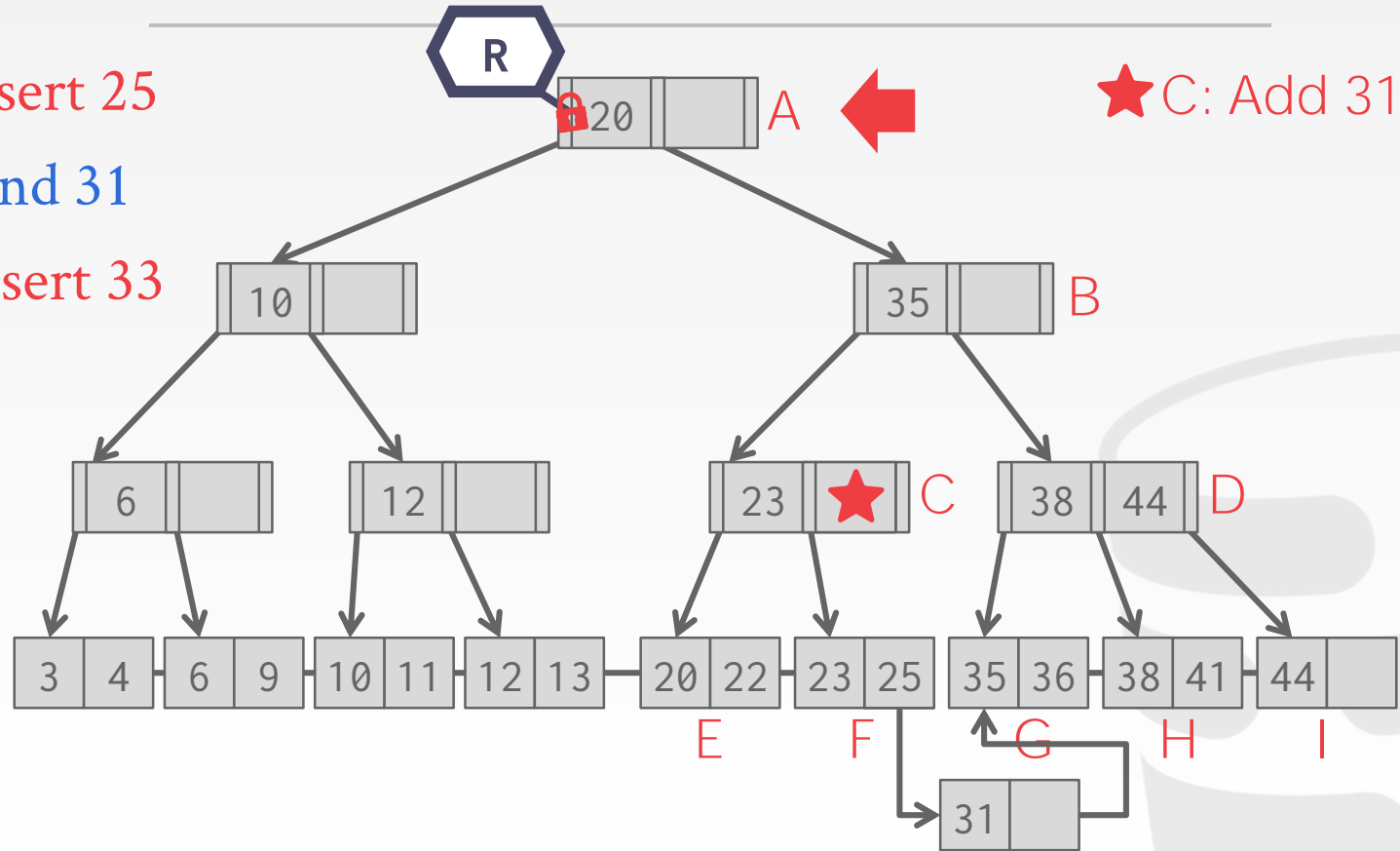

# EXAMPLE #4 – INSERT 25

$T_1$ : Insert 25

$T_2$ : Find 31

$T_3$ : Insert 33

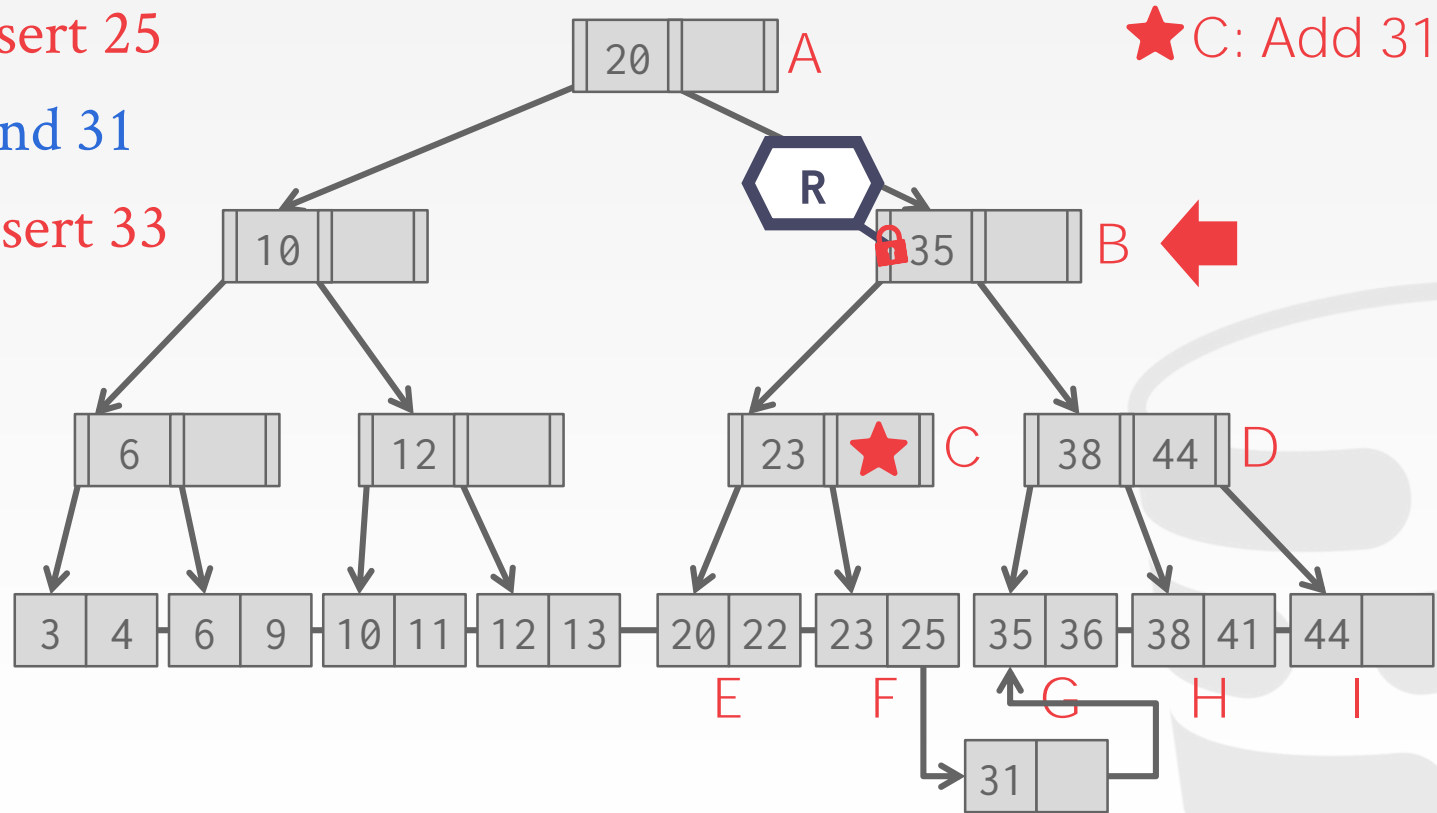

# EXAMPLE #4 – INSERT 25

$T_1$ : Insert 25

$T_2$ : Find 31

$T_3$ : Insert 33

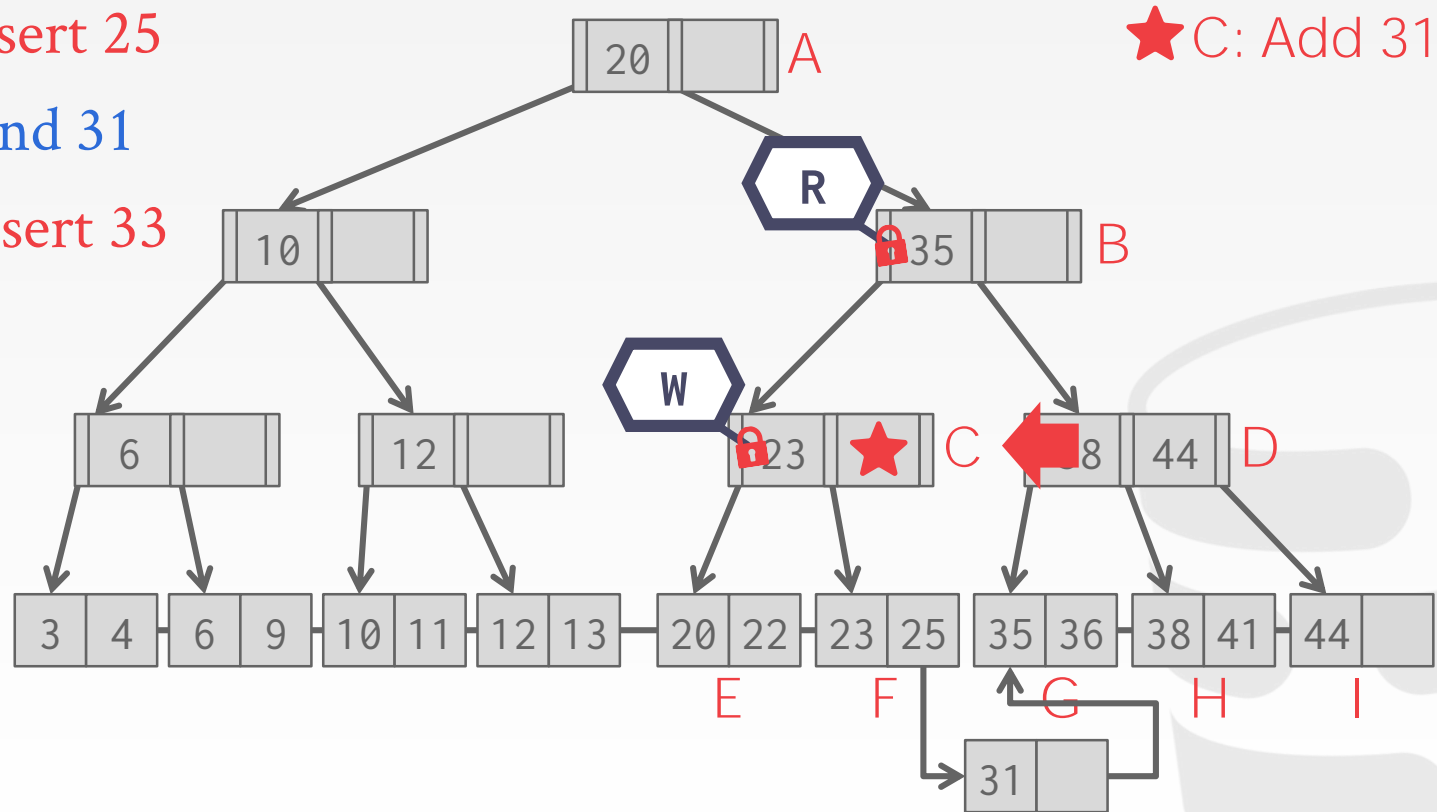

# EXAMPLE #4 – INSERT 25

$T_1$ : Insert 25

$T_2$ : Find 31

$T_3$ : Insert 33

★ C: Add 31

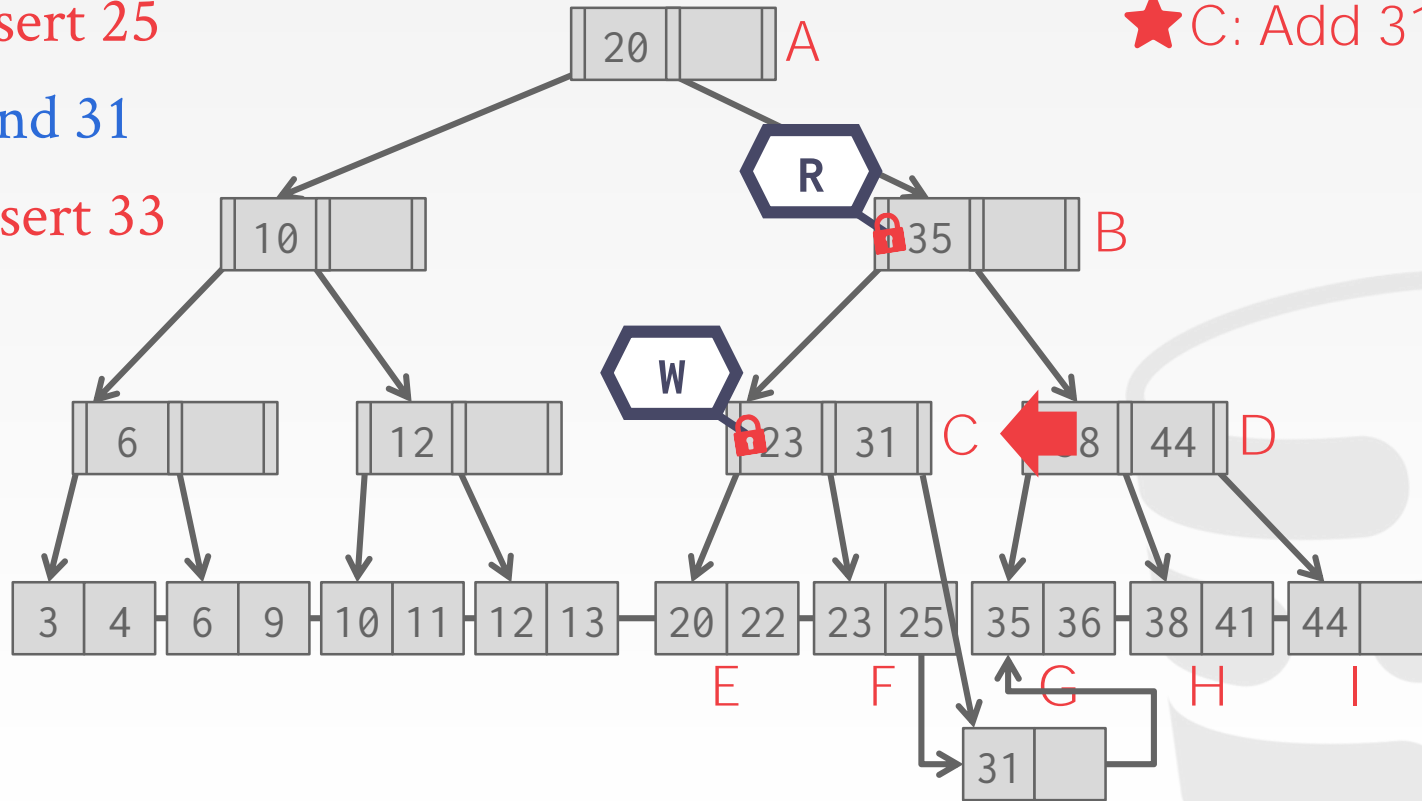

# EXAMPLE #4 – INSERT 25

$T_1$ : Insert 25

$T_2$ : Find 31

$T_3$ : Insert 33

★ C: Add 31

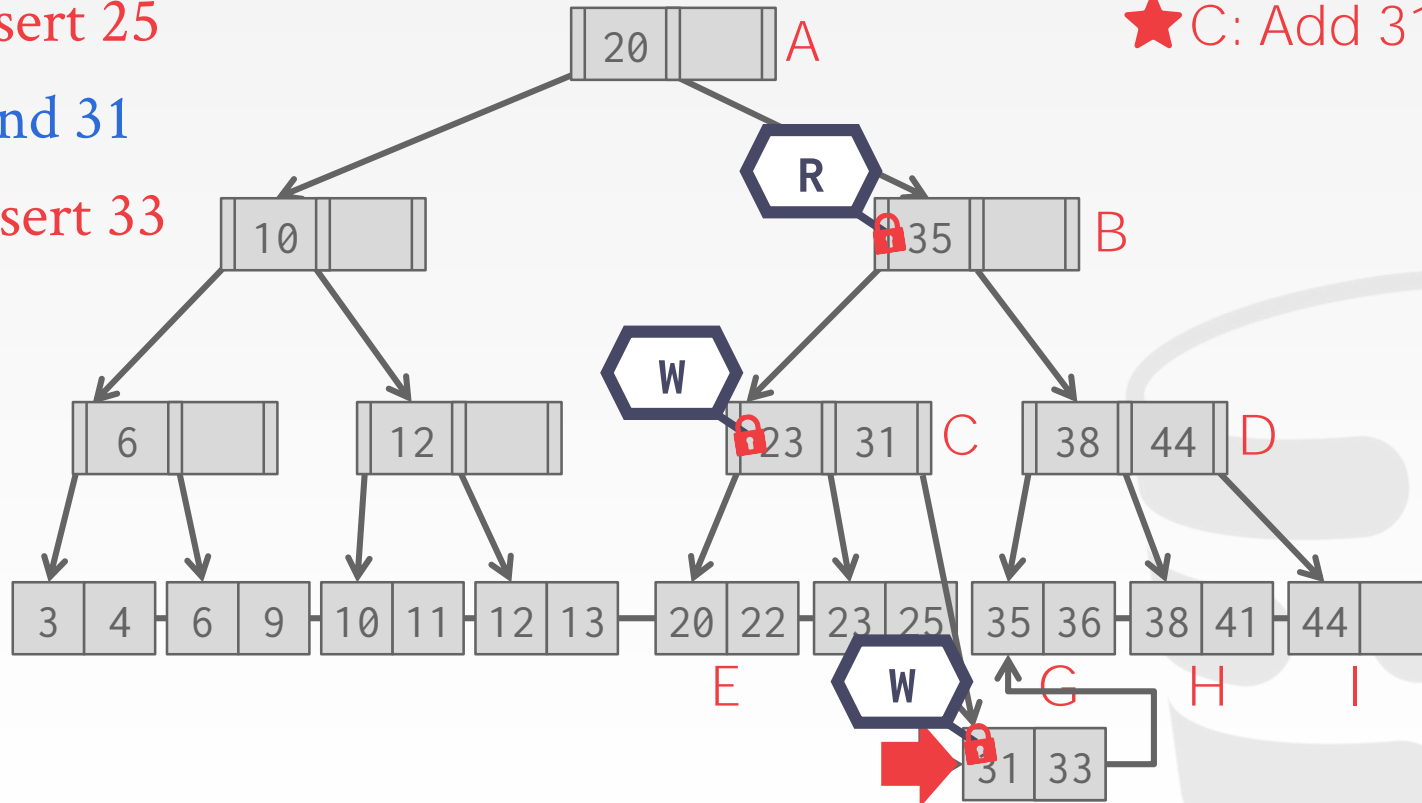

# CONCLUSION

---

Making a data structure thread-safe is notoriously difficult in practice.

We focused on B+Trees but the same high-level techniques are applicable to other data structures.



# NEXT CLASS

---

We are finally going to discuss how to execute some queries...

